

## FOREWORD

This handbook contains information on the Triumph Rocket III motorcycle. Always store this owner's handbook with the motorcycle and refer to it for information whenever necessary.

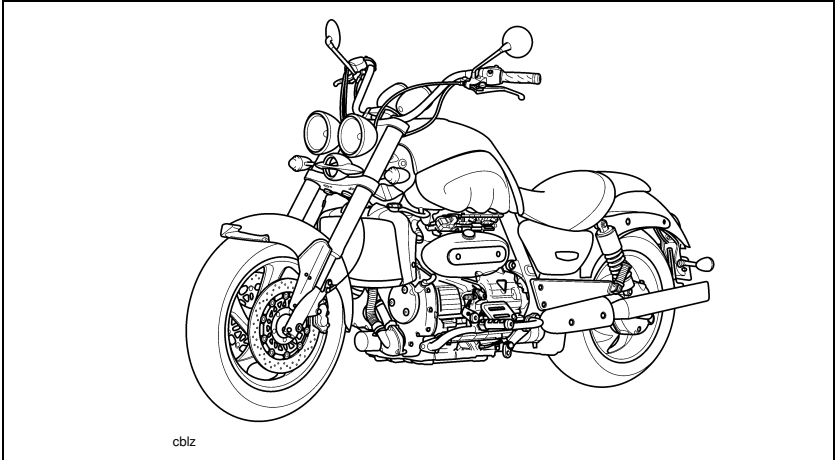

### Warning, Caution and Note

Throughout this owner's handbook particularly important information is presented in the following form:



#### Warning

This warning symbol identifies special instructions or procedures, which if not correctly followed could result in personal injury, or loss of life.



#### Caution

This caution symbol identifies special instructions or procedures, which, if not strictly observed, could result in damage to, or destruction of, equipment.

#### NOTE

- This note symbol indicates points of particular interest for more efficient and convenient operation.

## Warning Labels

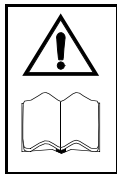

At certain areas of the motorcycle, the symbol (right) can be seen. The symbol means 'CAUTION: REFER TO THE HANDBOOK' and

will be followed by a pictorial representation of the subject concerned.

Never attempt to ride the motorcycle or make any adjustments without reference to the relevant instructions contained in this handbook.

See pages 12 and 13 for the location of all labels bearing this symbol. Where necessary, this symbol will also appear on the pages containing the relevant information.

## Maintenance

To ensure a long, safe and trouble free life for your motorcycle, maintenance should only be carried out by an authorised Triumph dealer.

Only an authorised Triumph dealer will have the necessary knowledge, equipment and skills to maintain your Triumph motorcycle correctly.

To locate your nearest Triumph dealer, visit the Triumph web-site at [www.triumph.co.uk](http://www.triumph.co.uk) or telephone the authorised distributor in your country.

Their address is given in the service record book that accompanies this handbook.

## Noise Control System

Tampering With the Noise Control System is Prohibited

Owners are warned that the law may prohibit:

- a) The removal or rendering inoperative by any person other than for purposes of maintenance, repair or replacement, of any device or element of design incorporated into any new vehicle for the purpose of noise control prior to its sale or delivery to the ultimate purchaser or while it is in use and,
- b) the use of the vehicle after such device or element of design has been removed or rendered inoperative by any person.

## Owner's Handbook

Thank you for choosing a Triumph motorcycle. This motorcycle is the product of Triumph's use of proven engineering, exhaustive testing, and continuous striving for superior reliability, safety and performance. Please read this owner's handbook before riding in order to become

thoroughly familiar with the correct operation of your motorcycle's controls, its features, capabilities and limitations.

This handbook includes safe riding tips, but does not contain all the techniques and skills necessary to ride a motorcycle safely. Triumph strongly recommends that all riders undertake the necessary training to ensure safe operation of this motorcycle.



## Warning

This owner's handbook, and all other instructions that are supplied with your motorcycle, should be considered a permanent part of your motorcycle and should remain with it even if your motorcycle is subsequently sold.

All riders must read this owner's handbook and all other instructions which are supplied with your motorcycle, before riding, in order to become thoroughly familiar with the correct operation of your motorcycle's controls, its features, capabilities and limitations. Do not lend your motorcycle to others as riding when not familiar with your motorcycle's controls, features, capabilities and limitations can lead to an accident.

## Information

The information contained in this publication is based on the latest information available at the time of printing. Triumph reserves the right to make changes at any time without prior notice, or obligation.

Not to be reproduced wholly or in part without the written permission of Triumph Motorcycles Limited.

© Copyright 2005 Triumph Motorcycles Limited, Hinckley, Leicestershire, England.

Publication part number 3850351 issue 4.

## Table of Contents

This handbook contains a number of different sections. The table of contents below will help you find the beginning of each section where, in the case of the major sections, a further table of contents will help you find the specific subject required.

Foreword .....	1
Warning Labels .....	12
Parts Identification .....	14
Serial Numbers .....	17
General Information .....	19
How to Ride the Motorcycle .....	35
Accessories, Loading and Passengers .....	47
Maintenance and Adjustment .....	51
Storage .....	93
Specifications .....	95

## FOREWORD - SAFETY FIRST

### The Motorcycle



#### Warning

This motorcycle is designed for on-road use only. It is not suitable for off-road use.

Off-road operation could lead to loss of control of the motorcycle resulting in an accident causing injury or loss of life.



#### Warning

This motorcycle is not designed to tow a trailer or be fitted with a sidecar. Fitting a sidecar and/or a trailer may result in loss of control and an accident.



#### Warning

This motorcycle is designed for use as a two-wheeled vehicle capable of carrying a rider on his/her own, or a rider and one passenger (subject to a passenger seat being fitted).

The total weight of the rider, and any passenger, accessories and luggage must not exceed the maximum load limit of 235 kg.

### Fuel and Exhaust Fumes



#### Warning

#### **PETROL IS HIGHLY FLAMMABLE:**

Always turn off the engine when refuelling.

Do not refuel or open the fuel filler cap while smoking or in the vicinity of any open (naked) flame.

Take care not to spill any petrol on the engine, exhaust pipes or silencers when refuelling.

If petrol is swallowed, inhaled or allowed to get into the eyes, seek immediate medical attention.

Spillage on the skin should be immediately washed off with soap and water and clothing contaminated with petrol should immediately be removed.

Burns and other serious skin conditions may result from contact with petrol.



#### Warning

Never start your engine or let it run for any length of time in a closed area. The exhaust fumes are poisonous and may cause loss of consciousness and death within a short time. Always operate your motorcycle in the open-air or in an area with adequate ventilation.

## Safety Helmet and Clothing



### Warning

When riding the motorcycle, both rider and passenger must always wear a motorcycle safety helmet, eye protection, gloves, trousers (close fitting around the knee and ankle) and a brightly coloured jacket. Brightly coloured clothing will considerably increase a rider's (or passenger's) visibility to other operators of road vehicles. Although full protection is not possible, wearing correct protective clothing can reduce the risk of injury when riding.



### Warning

A safety helmet is one of the most important pieces of riding gear as it offers protection against head injuries. You and your passenger's helmet should be carefully chosen and should fit you or your passenger's head comfortably and securely. A brightly coloured helmet will increase a rider's (or passenger's) visibility to other operators of road vehicles.

An open face helmet offers some protection in an accident though a full face helmet will offer more.

Always wear a visor or approved goggles to help vision and to protect your eyes.



cbma

## Parking



### Warning

Always turn off the engine and remove the ignition key before leaving the motorcycle unattended. By removing the key, the risk of use of the motorcycle by unauthorised or untrained persons is reduced.

When parking the motorcycle, always remember the following:

Engage first gear to help prevent the motorcycle from rolling off the stand.

The engine and exhaust system will be hot after riding. **DO NOT** park where pedestrians, animals and/or children are likely to touch the motorcycle.

Do not park on soft ground or on a steeply inclined surface. Parking under these conditions may cause the motorcycle to fall over.

For further details, please refer to the 'How to Ride the Motorcycle' section of this owner's handbook.

## Parts and Accessories



### Warning

Owners should be aware that the only approved parts, accessories and conversions for any Triumph motorcycle are those which carry official Triumph approval and are fitted to the motorcycle by an authorised dealer.

Triumph does not accept any liability whatsoever for defects caused by the fitting of non-approved parts, accessories or conversions or the fitting of any approved parts, accessories or conversions by non-approved personnel.

In particular, it is extremely hazardous to fit or replace parts or accessories whose fitting requires the dismantling of, or addition to, either the electrical or fuel systems and any such modification could cause a safety hazard.

The fitting of any non-approved parts, accessories or conversions may adversely affect the handling, stability or other aspect of the motorcycle operation that may result in an accident causing injury or death.

## Maintenance/Equipment



### Warning

Consult your authorised Triumph dealer whenever there is doubt as to the correct or safe operation of this Triumph motorcycle.

Remember that continued operation of an incorrectly performing motorcycle may aggravate a fault and may also prejudice safety.



### Warning

Use of a motorcycle with bank angle indicators worn beyond the maximum limit (when the bank angle indicator is worn to a minimum of 5 mm in length) will allow the motorcycle to be banked to an unsafe angle. Therefore, always replace the bank angle indicator pegs when they are worn to 5 mm in length. Banking to an unsafe angle may cause instability, loss of motorcycle control and an accident.

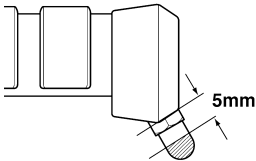

cbpm



### Warning

Ensure all equipment that is required by law is installed and functioning correctly. The removal or alteration of the motorcycle's lights, silencers, emission or noise control systems can violate the law. Incorrect or improper modification may adversely affect the handling, stability or other aspect of the motorcycle operation, which may result in an accident causing injury or death.



### Warning

If the motorcycle is involved in an accident, collision or fall, it must be taken to an authorised Triumph dealer for inspection and repair. Any accident can cause damage to the motorcycle that, if not correctly repaired, may cause a second accident that may result in injury or death.

## Riding



### Warning

Never ride the motorcycle when fatigued or under the influence of alcohol or other drugs.

Riding when under the influence of alcohol or other drugs is illegal.

Riding when fatigued or under the influence of alcohol or other drugs reduces the rider's ability to maintain control of the motorcycle and may lead to loss of control and an accident.



### Warning

All riders must be licensed to operate the motorcycle. Operation of the motorcycle without a licence is illegal and could lead to prosecution. In addition, operation without a licence is dangerous and may lead to loss of motorcycle control and an accident.



### Warning

Always ride defensively and wear the protective equipment mentioned elsewhere in this foreword. Remember, in an accident, a motorcycle does not give the same impact protection as a car.



### Warning

This Triumph motorcycle should be operated within the legal speed limits for the particular road travelled. Operating a motorcycle at high speeds can be potentially dangerous since the time available to react to given traffic situations is greatly reduced as road speed increases. Always reduce speed in potentially hazardous driving conditions such as bad weather or heavy traffic.



## Warning

Continually observe and react to changes in road surface, traffic and wind conditions. All two-wheeled vehicles are subject to external forces which may cause an accident. These forces include but are not limited to:

- Wind draft from passing vehicles.
- Uneven or holed road surfaces.
- Bad weather.
- Rider error.

Always operate the motorcycle at moderate speed and away from heavy traffic until you have become thoroughly familiar with its handling and operating characteristics. Never exceed the legal speed limit.

## Handlebars and Footrests



## Warning

The rider must maintain control of the vehicle by keeping hands on the handlebars at all times.

The handling and stability of a motorcycle will be adversely affected if the rider removes his hands from the handlebars, resulting in loss of motorcycle control and an accident.



## Warning

The rider and passenger must always use the footrests provided, during operation of the vehicle.

By using the footrests, both rider and passenger will reduce the risk of inadvertent contact with any motorcycle components and will also reduce the risk of injury from entrapment of clothing.

## WARNING LABELS

### Warning Label Locations – Rocket III

The labels detailed on this and the following pages draw your attention to important safety information in this handbook. Before riding, ensure that all riders have understood and complied with all the information to which these labels relate.

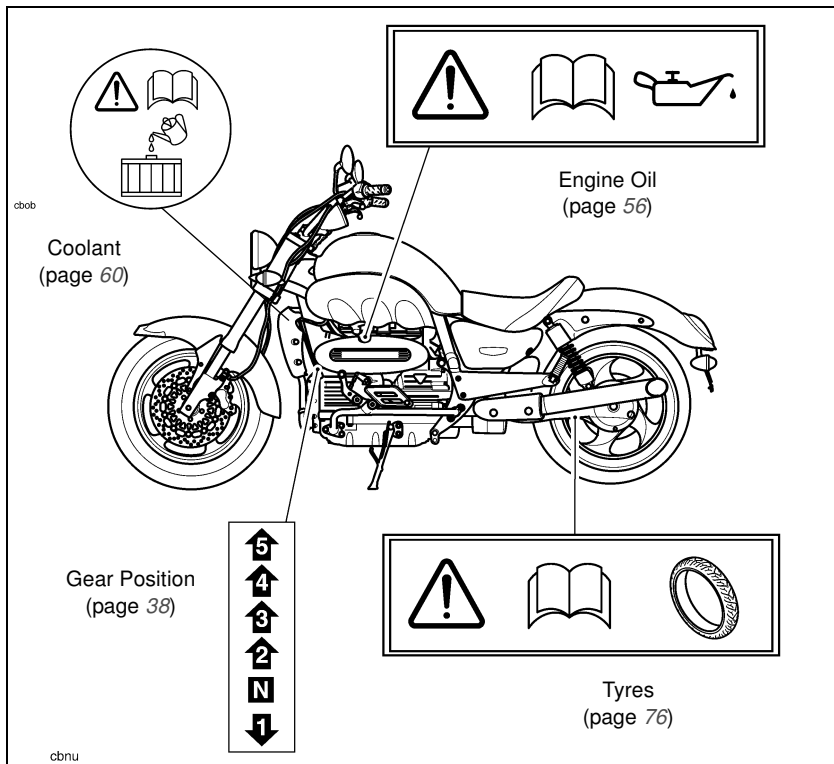

## Warning Label Locations – Rocket III (continued)



Unleaded Fuel  
(page 30)

Safety Helmet  
(page 7)



Daily Safety Checks  
(page 33)

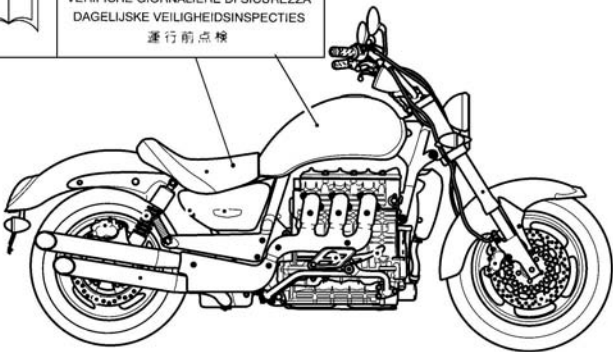

cbnv

## PARTS IDENTIFICATION

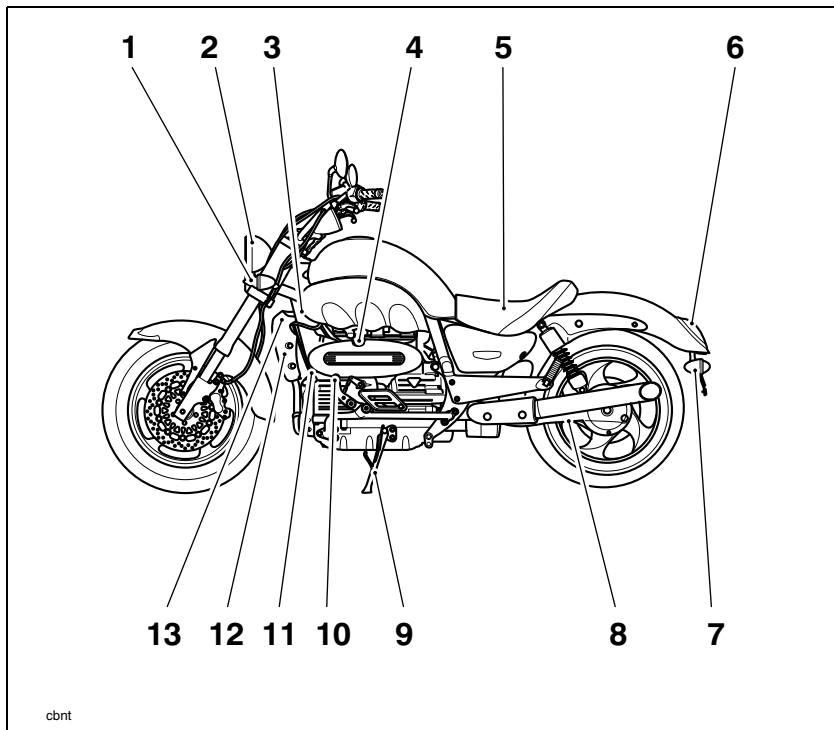

cbnt

- |                                       |                         |
|---------------------------------------|-------------------------|
| 1 Front Indicator                     | 9 Side Stand            |
| 2 Headlamps                           | 10 Gear Change Pedal    |
| 3 Coolant Expansion Tank              | 11 Clutch Cable         |
| 4 Oil Filler Cap/Dipstick             | 12 Radiator             |
| 5 Tool Kit beneath seat)              | 13 Coolant Pressure Cap |
| 6 Rear Lamp                           |                         |
| 7 Rear Indicator                      |                         |
| 8 Transmission Shaft/Final Drive Unit |                         |

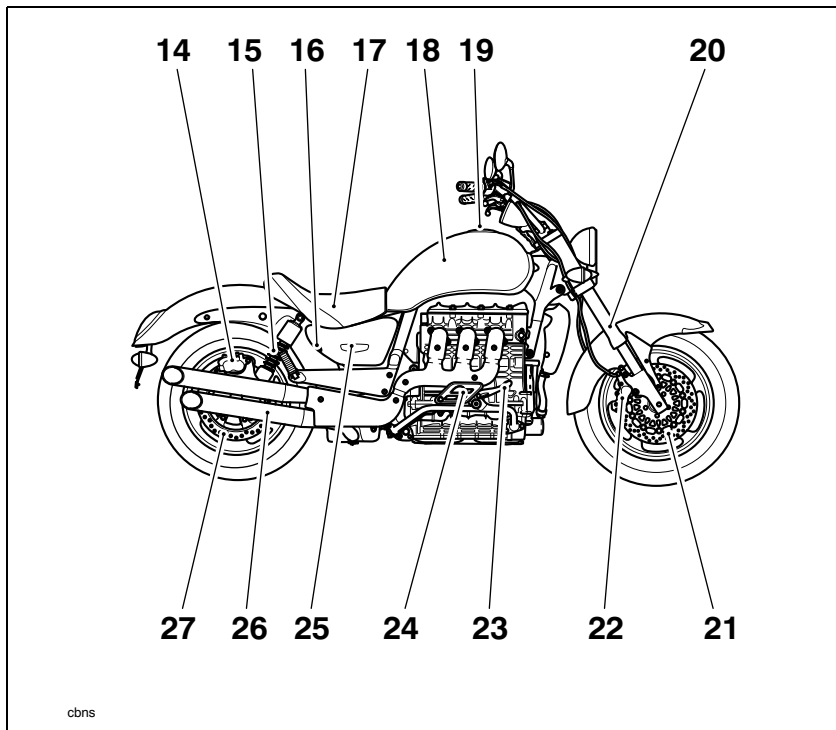

cbns

- |    |                        |    |  |
|----|------------------------|----|--|
| 14 | Rear Brake Caliper     | 22 | Front Brake Caliper                                      |
| 15 | Rear Suspension Unit   | 23 | Rear Brake Pedal   |
| 16 | Seat Lock              | 24 | Rear Brake Fluid Reservoir                               |
| 17 | Battery (beneath seat) | 25 | Engine Management ECM<br>(beneath right hand side panel) |
| 18 | Fuel Tank              | 26 | Silencer   |
| 19 | Fuel Filler Cap        | 27 | Rear Brake Disc  |
| 20 | Front Fork             |    |  |
| 21 | Front Brake Disc       |    |  |

# Parts Identification

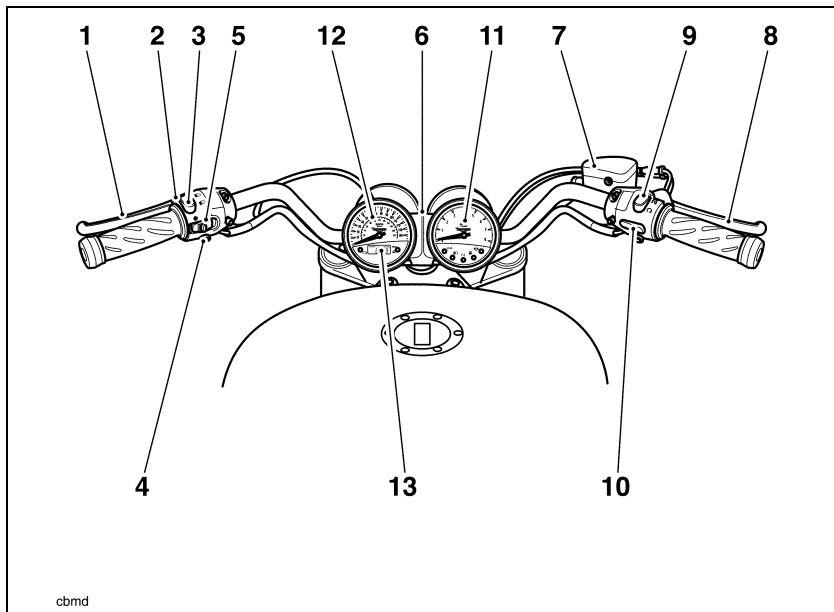

cbmd

- 1 Clutch Lever
- 2 Clutch Lever Adjuster
- 3 Headlamp Dipswitch
- 4 Horn Button
- 5 Indicator Switch
- 6 Ignition Switch
- 7 Front Brake Fluid Reservoir
- 8 Front Brake Lever
- 9 Engine Stop Switch
- 10 Starter Button
- 11 Tachometer
- 12 Speedometer
- 13 Odometer

## SERIAL NUMBERS

### Vehicle Identification Number (V.I.N.)

The vehicle identification number is stamped into the steering head area of the frame. It is also displayed on a plate, riveted to the frame, beneath the rider's seat.

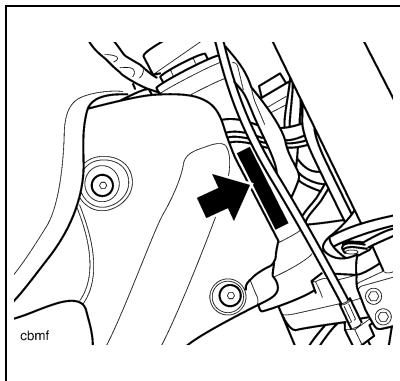

### Engine Serial Number

The engine serial number is stamped on the engine crankcase, towards the rear, on the right hand side.

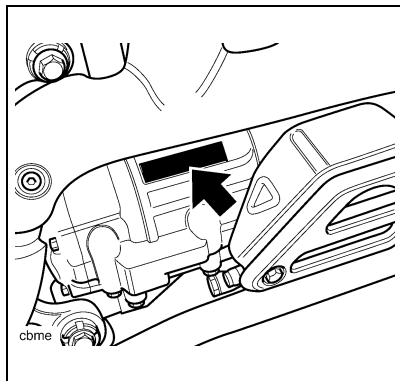

This page intentionally left blank

# GENERAL INFORMATION

## Table of Contents

Instrument Panel Layout .....	20
Speedometer .....	21
Tachometer .....	21
Odometer/Trip Meter .....	21
Warning Lights .....	22
Low Oil Pressure Warning .....	22
Coolant Temperature .....	22
Ignition Key .....	24
Ignition Switch/Steering Lock .....	24
Ignition Switch Positions .....	24
Brake and Clutch Lever Adjuster .....	25
Right Handlebar Switches .....	26
Engine Stop Switch .....	26
Starter Button .....	27
Left Handlebar Switches .....	27
Headlight Dip Switch .....	27
Direction Indicator Switch .....	27
Horn Button .....	27
Fuel Requirement/Refuelling .....	28
Fuel Grade .....	28
Fuel Tank Cap .....	29
Filling the Fuel Tank .....	30
Stand .....	31
Side Stand .....	31
Tool Kit and Handbook .....	31
Seat Lock .....	32
Running-In .....	32
Safe Operation .....	33
Daily Safety Checks .....	33

## Instrument Panel Layout

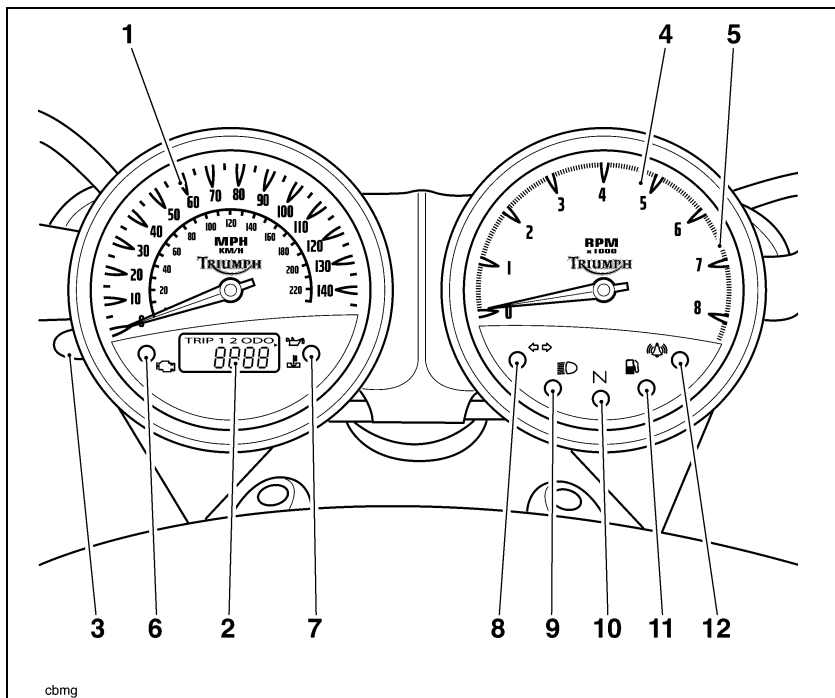

cbmg

- |   |  |    |   |
|---|--|----|---|
| 1 | Speedometer  | 9  | High Beam Indicator Light                                   |
| 2 | Odometer/Trip Meter  | 10 | Neutral Indicator Light                                     |
| 3 | Trip reset knob  | 11 | Low Fuel Level Indicator Light                              |
| 4 | Tachometer   | 12 | Alarm Status Indicator Light<br>(alarm is an accessory fit) |
| 5 | Tachometer 'red zone'                                      |    |   |
| 6 | Engine Management<br>Malfunction Indicator Light           |    |   |
| 7 | High Coolant Temperature/Low<br>Oil Pressure Warning Light |    |   |
| 8 | Turn Indicator light                                       |    |   |

## Speedometer

The speedometer indicates the road speed of the motorcycle.

## Tachometer

The tachometer shows the engine speed in revolutions per minute - rpm (r/min). On the right side of the tachometer face is the 'red zone'. Engine rpm (r/min) in the red zone is above maximum recommended engine speed and is also above the range for best performance.



### Caution

Never allow engine RPM to enter the 'red zone' as severe engine damage may result.

## Odometer/Trip Meter

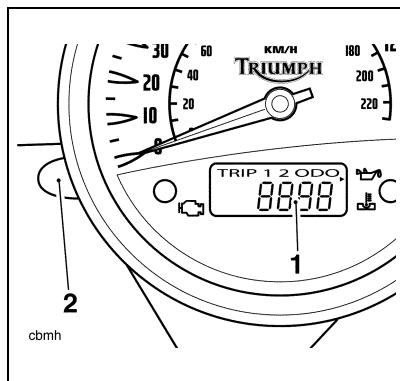

- 1 Odometer/trip meter display
- 2 Reset knob

The odometer shows the total distance that the motorcycle has travelled.

There are two trip meters. Either trip meter shows the distance that the motorcycle has travelled since the meter on display was last reset to zero.

To switch between the odometer and trip meter display modes, turn the reset knob anti-clockwise (as viewed from the left side of the motorcycle) and release when the desired display is visible. The display will scroll through in the order:

- Odometer
- Trip meter 1
- Trip meter 2

## General Information

To reset either of the trip meters, select and display the trip meter to be zeroed then turn the reset knob anti-clockwise (as viewed from the left side of the motorcycle) and hold it in the forward position for 2 seconds. After 2 seconds, the trip meter on display will reset to zero.

## Warning Lights

### **Low Oil Pressure Warning**

With the engine running, if the engine oil pressure becomes dangerously low, the high coolant temperature/low oil pressure warning light will illuminate and an arrow will appear on the digital display pointing to the low oil pressure warning symbol.

### **Caution**

Stop the engine immediately if the low oil pressure warning light illuminates. Do not restart the engine until the fault has been rectified.

Severe engine damage will result from running the engine when the low oil pressure warning light is illuminated.

## NOTE

- **The high coolant temperature /low oil pressure warning light will illuminate and an arrow will appear on the digital display along side the low oil pressure warning symbol, if the ignition is switched on without running the engine.**

### **Coolant Temperature**

If the coolant temperature becomes too high, the high coolant temperature/low oil pressure warning light will illuminate and an arrow will appear on the digital display pointing to the high coolant temperature symbol.

### **Caution**

Do not continue to run the engine if the high coolant temperature warning is illuminated as severe engine damage may result.

### **Engine Management System Malfunction Indicator Light**

The malfunction indicator light for the engine management system illuminates when the ignition is switched on (to indicate that it is working) but should not become

illuminated when the engine is running.

If the malfunction indicator light becomes illuminated when the engine is running, this indicates that a fault has occurred in one or more of the systems controlled by the engine management system. In such circumstances, the engine management system will switch to 'limp-home' mode so that the journey may be completed, if the fault is not so severe that the engine will not run.



### Warning

Reduce speed and do not continue to ride for longer than is necessary with the malfunction indicator light illuminated. The fault may adversely affect engine performance, exhaust emissions and fuel consumption. Reduced engine performance could cause a dangerous riding condition, leading to loss of control and an accident. Contact an authorised Triumph dealer as soon as possible to have the fault checked and rectified.

### Turn Indicators



When the indicator switch is turned to left or right, the turn indicator light will flash on and off at the same speed as the turn indicators.



### High Beam

When the ignition is switched on and the headlight dip switch is set to 'high beam', the high beam warning light will illuminate.



### Neutral

The neutral warning light indicates when the transmission is in neutral (no gear selected). The warning light will illuminate when the transmission is in neutral with the ignition switch in the 'ON' position.



### Low Fuel

The low fuel indicator will illuminate when there are approximately 7.0 litres of fuel remaining in the tank.



### Alarm

The alarm light will illuminate when the conditions described in the accessory alarm instructions are met.

## Ignition Key

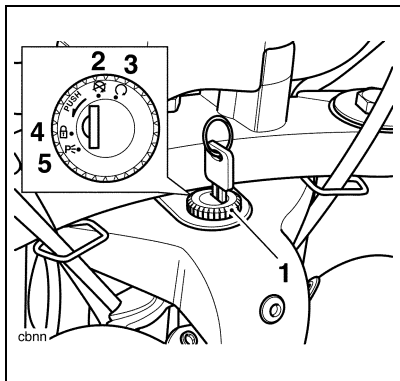

- 1 Steering lock
- 2 Off position
- 3 On position
- 4 Lock position
- 5 Park position

In addition to operating the steering lock/ignition switch, the ignition key is required to operate the seat lock and fuel tank cap.

When the motorcycle is delivered from the factory, two keys are supplied together with a small tag bearing the key number. Make a note of the key number and store the spare key and key number tag in a safe place away from the motorcycle.

Your authorised Triumph dealer can supply a replacement key cut from details of the key number or can cut a new key using the original as a master.



## Caution

Do not store the spare key with the motorcycle as this will reduce all aspects of security.

## Ignition Switch/Steering Lock

### Ignition Switch Positions

This is a four position, key operated switch. The key can be removed from the switch only when it is in the OFF, LOCK or P (PARK) position.

**TO LOCK:** Turn the key to the 'OFF' position, push and fully release the key, then rotate it to the 'LOCK' position.

**'PARKING':** Turn the key from the 'LOCK' position to the 'P' position. The steering will remain locked.

### NOTE

- **Do not leave the steering lock in the 'P' position for long periods of time as this will cause the battery to discharge.**



## Warning

For reasons of security and safety, always move the ignition switch to the 'LOCK' or 'P' position and remove the key, when leaving the motorcycle unattended.

Any unauthorised use of the motorcycle may cause injury to the rider, other road users and pedestrians and may also cause damage to the motorcycle.



## Warning

With the key in the 'LOCK' or 'P' position the steering will become locked.

Never turn the key to the 'Lock' or 'P' positions while the motorcycle is moving as this will cause the steering to lock. Locked steering will cause loss of motorcycle control and an accident.

## Brake and Clutch Lever Adjuster

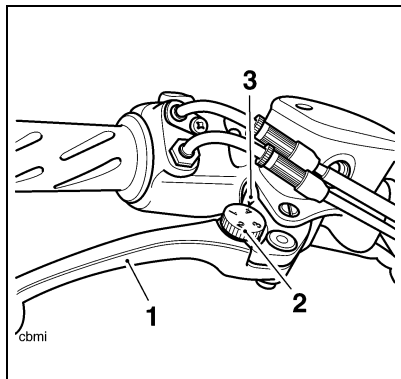

- 1 Lever
- 2 Adjuster wheel
- 3 Triangular mark

An adjuster is fitted to the front brake and clutch levers. The adjusters allow the distance from the handlebar to the levers to be changed to one of four positions, to suit the span of the operator's hands.

To adjust the levers, push each lever forward and turn the adjuster wheel to align one of the numbered positions with the triangular mark on the lever holder.

The distance from the handlebar grip to the released lever is shortest when set to number four and longest when set to number one.



### Warning

Do not attempt to adjust the levers with the motorcycle in motion as this may lead to loss of motorcycle control and an accident.

After adjusting the levers, operate the motorcycle in an area free from traffic to gain familiarity with the new lever setting. Do not loan your motorcycle to anyone as they may change the lever setting from the one you are familiar with causing loss of control or an accident.

## Right Handlebar Switches

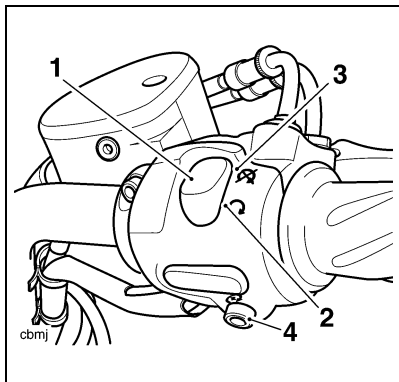

- 1 Engine stop switch
- 2 'Run' position
- 3 'Stop' position
- 4 Starter button

## Engine Stop Switch

In addition to the ignition switch being turned to the 'ON' position, the engine stop switch must be in the 'run' position for the motorcycle to operate.

The engine stop switch is for emergency use. If an emergency arises which requires the engine to be stopped, move the engine stop switch to the stop position.

### NOTE

- Although the engine stop switch stops the engine, it does not turn off all the electrical circuits and may cause difficulty in restarting the engine due to a discharged battery. Ordinarily, only the ignition switch should be used to stop the engine.



### Caution

Do not leave the ignition switch in the 'ON' position unless the engine is running as this may cause damage to electrical components and will discharge the battery.

## Starter Button

The starter button operates the electric starter. For the starter to operate, the clutch lever must be pulled to the handlebar.

### NOTE

- Even if the clutch lever is pulled to the handlebar, the starter will not operate if the side stand is down and a gear is engaged.

## Left Handlebar Switches

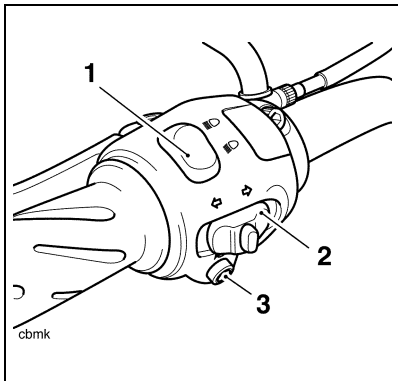

- 1 Headlight dipswitch
- 2 Direction indicator switch
- 3 Horn button

## Headlight Dip Switch

High or low beam can be selected with the headlight dip switch. To select high beam, push the switch

forward. To select low beam, push the switch rearwards. When the high beam is turned on, the high beam indicator light will illuminate.

### NOTE

- A lighting ON/OFF switch is not fitted to this model. The headlight, rear light and licence plate light all function automatically when the ignition is turned to the ON position.

## Direction Indicator Switch

When the indicator switch is pushed to the left or right and released, the corresponding direction indicators will flash on and off. To turn off the indicators, push and release the switch.

## Horn Button

When the horn button is pushed, with the ignition switch turned to the 'ON' position, the horn will sound.

## Fuel Requirement/ Refuelling



cbnv

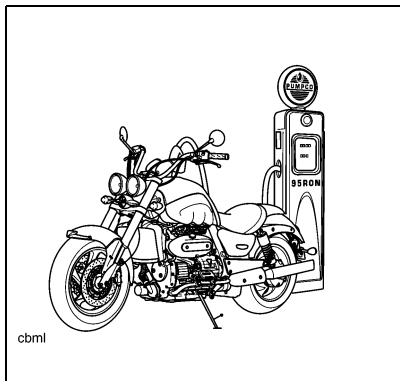

cbml

## Fuel Grade

Your Triumph engine is designed to use unleaded fuel and will give optimum performance if the correct grade of fuel is used. Always use unleaded fuel with an octane rating of 95 RON.



## Caution

In many countries, the exhaust system for this model is fitted with a catalytic converter to help reduce exhaust emission levels. The catalytic converter can be permanently damaged if the motorcycle is allowed to run out of fuel or if the fuel level is allowed to get very low. Always ensure you have adequate fuel for your journey.



## Caution

The use of leaded fuel is illegal in some countries, states or territories. Use of leaded fuel will damage the catalytic converter (if fitted).



## Warning

To help reduce hazards associated with refuelling, always observe the following fuel safety instructions:

Petrol (fuel) is highly flammable and can be explosive under certain conditions. When refuelling, turn the ignition switch to the 'OFF' position.

Do not smoke.

Make sure the refuelling area is well ventilated and free from any source of flame or sparks. This includes any appliance with a pilot light.

Never fill the tank until the fuel level rises into the filler neck. Heat from sunlight or other sources may cause the fuel to expand and overflow creating a fire hazard.

After refuelling always check that the fuel filler cap is correctly closed and locked.

Because petrol (fuel) is highly flammable, any fuel leak or spillage, or any failure to observe the safety advice given above will lead to a fire hazard, which could cause damage to property, injury to persons or death.

## Fuel Tank Cap

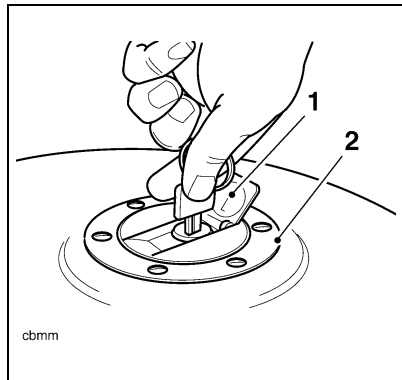

- 1 Fuel tank cap
- 2 Key

To open the fuel tank cap, lift up the flap covering the lock itself. Insert the key into the lock and turn the key clockwise.

To close and lock the cap, push the cap down into place with the key inserted, until the lock 'clicks' into place. Withdraw the key and close the key cover.



## Caution

Closing the cap without the key inserted will damage the cap, tank and lock mechanism.

## Filling the Fuel Tank

Avoid filling the tank in rainy or dusty conditions where airborne material can contaminate the fuel.



### Caution

Contaminated fuel may cause damage to fuel system components.

Fill the fuel tank slowly to help prevent spillage. Do not fill the tank to a level above the bottom of the filler neck. This will ensure there is enough air space to allow for fuel expansion if the fuel inside the tank expands through absorption of heat from the engine or from direct sunlight.

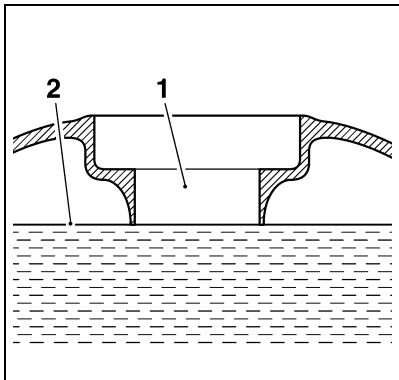

- 1 Fuel filler neck
- 2 Maximum fuel level

After refuelling always check that the fuel filler cap is correctly closed and locked.



### Warning

Overfilling the tank can lead to fuel spillage.

If fuel is spilled, thoroughly clean up the spillage immediately and dispose of the materials used safely.

Take care not to spill any fuel on the engine, exhaust pipes, tyres or any other part of the motorcycle.

Because fuel is highly flammable, any fuel leak or spillage, or any failure to observe the safety advice given above may lead to a fire hazard, which could cause damage to property and injury or death to persons.

Fuel spilled near to, or onto the tyres will reduce the tyre's ability to grip the road. This will give rise to a dangerous riding condition potentially causing loss of motorcycle control and an accident.

## Stand

### Side Stand

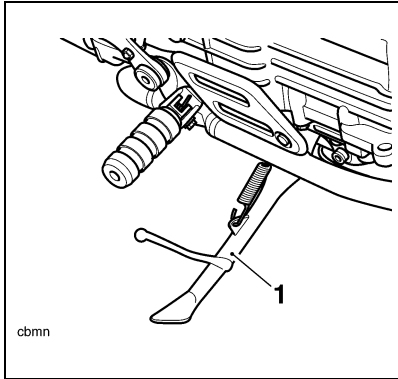

1 Side stand

The motorcycle is equipped with a side stand on which the motorcycle can be parked.



### Warning

The motorcycle is fitted with an interlock system to prevent it from being ridden with the side stand in the down position.

Never attempt to ride with the side stand down or interfere with the interlock mechanism as this will cause a dangerous riding condition leading to loss of motorcycle control and an accident.

### NOTE

- When using the side stand, always turn the handlebars fully to the left and leave the motorcycle in first gear.

Whenever the side stand is used before riding, always ensure that the stand is fully up after first sitting on the motorcycle.

For instructions on safe parking, refer to the 'How to Ride the Motorcycle' section.

## Tool Kit and Handbook

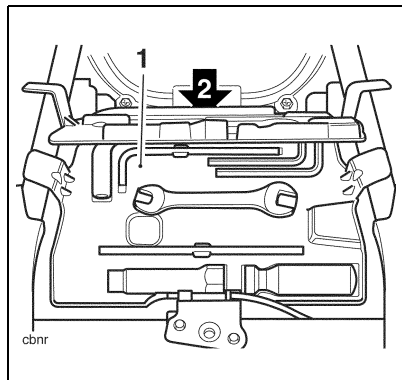

1 Tool kit tray

2 Handbook location

The tool kit is located in a dedicated box beneath the rider's seat.

## General Information

To gain access to the handbook, remove the rear seat (as described elsewhere in this section) and pivot the toolbox upward towards the rear of the motorcycle. The handbook is located in a vertical slot behind the battery.

### Seat Lock

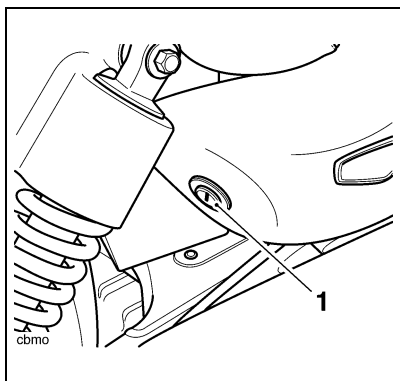

1 Seat lock

The seat lock is located at the rear of the right hand side cover. To remove the seat, insert the ignition key into the seat lock and turn it anti-clockwise while pressing down on the rear of the seat. This will release the seat from its lock and allow it to be slid rearwards for complete removal from the motorcycle.

To refit the seat, engage the seat's tongue under the fuel tank and press

down at the rear to engage in the seat lock.



### Warning

To prevent detachment of the seat during riding, after fitting always grasp the seat and pull firmly upwards. If the seat is not correctly secured in the lock it will detach from the lock. A loose or detached seat could cause loss of motorcycle control and an accident.

### Running-In

Running-in is the name given to the process that occurs during the first hours of a new vehicle's operation.

In particular, internal friction in the engine will be higher when components are new. Later on, when continued operation of the engine has ensured that the components have 'bedded in', this internal friction will be greatly reduced.

A period of careful running in will ensure lower exhaust emissions, and will optimise performance, fuel economy and longevity of the engine and other motorcycle components.

During the first 500 miles (800 kilometres):

- Do not use full throttle.
- Avoid high engine speeds at all times.
- Avoid riding at one constant engine speed, whether fast or slow, for a long period of time.
- Avoid aggressive starts, stops, and rapid accelerations, except in an emergency.
- Do not ride at speeds greater than 3/4 of maximum speed.

From 500 to 1000 miles (800 to 1500 kilometres):

- Engine speed can gradually be increased to the rev limit for short periods.
- Both during and after running in has been completed:-
- Do not over-rev the engine when cold.
- Do not let the engine labour. Always downshift before the engine begins to 'struggle'.
- Do not ride with engine speeds unnecessarily high. Changing up a gear helps reduce fuel consumption, reduces noise and helps to protect the environment.

## Safe Operation



cbob

## Daily Safety Checks

Check the following items each day before you ride. The time required is minimal, and these checks will help ensure a safe, reliable ride.

If any irregularities are found during these checks, refer to the Maintenance and Adjustment section or see your authorised Triumph dealer for the action required to return the motorcycle to a safe operating condition.



## Warning

Failure to perform these checks every day before you ride may result in serious motorcycle damage or an accident causing serious injury or death.

### Check:-

**Fuel:** Adequate supply in tank, no fuel leaks (page 28).

**Engine oil:** Correct level on dipstick. Add correct specification oil as required. No leaks from the engine or oil cooler (page 56).

## General Information

---

**Final drive:** No oil leaks (page 75).

**Tyres/Wheels:** Correct inflation pressures (when cold). Tread depth/wear, tyre/wheel damage, punctures etc. (page 76).

**Nuts, bolts, fasteners:** Visually check that steering and suspension components, axles, and all controls are properly tightened or fastened. Inspect all areas for loose/damaged fixings.

**Steering Action:** smooth but not loose from lock to lock. No binding of any of the control cables (page 71).

**Brakes:** Pull the brake lever and push the brake pedal to check for correct resistance. Investigate any lever/pedal where the travel is excessive before meeting resistance, or if either control feels spongy in operation (page 67).

**Brake pads:** There should be more than 1.5 mm of friction material remaining on all the pads (page 67).

**Brake Fluid Levels:** No brake fluid leakage. Brake fluid levels must be between the 'max' and 'min' marks on both reservoirs (page 69).

**Front Forks:** Smooth action. No leaks from fork seals (page 73).

**Throttle:** Throttle grip free-play 2-3 mm. Ensure that the throttle grip returns to the idle position without sticking (page 63).

**Clutch:** Smooth operation and correct cable free-play (page 66).

**Coolant:** No coolant leakage. Check the coolant level in the expansion tank (when the engine is cold) (page 60).

**Electrical equipment:** All lights and horn function correctly (page 24).

**Engine stop:** Stop switch turns the engine off (page 36).

**Stands:** Return to the fully up position by spring tension. Return springs not weak or damaged (page 31).

## HOW TO RIDE THE MOTORCYCLE

### Table of Contents

To Stop the Engine.....	36
To Start the Engine .....	37
Moving Off .....	38
Changing Gears .....	38
Braking .....	39
Parking .....	42
Considerations for High Speed Operation.....	43
General .....	44
Steering.....	44
Luggage.....	44
Brakes.....	44
Tyres .....	44
Fuel.....	44
Engine Oil .....	45
Final Drive Oil .....	45
Coolant .....	45
Electrical Equipment.....	45
Miscellaneous .....	45

## To Stop the Engine

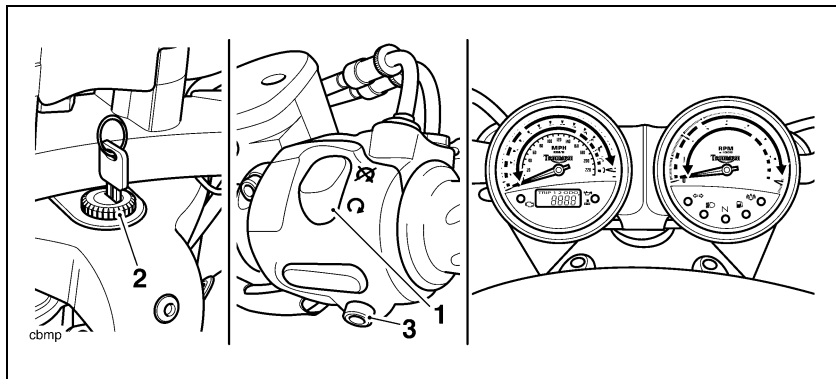

- 1 Engine stop switch
- 2 Ignition switch
- 3 Starter button

Support the motorcycle on a firm, level surface with the side stand.

Close the throttle completely.

Select neutral.

Turn the ignition switch off.

Lock the steering.



### Caution

The engine should normally be stopped by turning the ignition switch to the off position. The engine stop switch is for emergency use only. Do not leave the ignition switched on with the engine stopped. Electrical damage may result.

## To Start the Engine

Check that the engine stop switch is in the run position.

Ensure the transmission is in neutral.

Pull the clutch lever fully into the handlebar.

Turn the ignition switch on.

### NOTE

- **When the ignition is switched on, the speedometer and tachometer needles will quickly sweep from zero to maximum and then return to zero. The instrument warning lights will illuminate and will then go off (except those which normally remain on until the engine starts – see ‘warning lights’ on page 22). It is not necessary to wait for the needles to return to zero before starting the engine.**



## Warning

Never start the engine or run the engine in a confined area. Exhaust fumes are poisonous and can cause loss of consciousness and death within a short period of time. Always operate your motorcycle in the open-air or in an area with adequate ventilation.



## Caution

Do not operate the starter continuously for more than 5 seconds as the starter motor will overheat and the battery will become discharged. Wait 15 seconds between each operation of the starter to allow for cooling and recovery of battery power.

Do not let the engine idle for long periods as this may lead to overheating which will cause damage to the engine.



## Caution

The low oil pressure warning light should go out shortly after the engine starts.

If the low oil pressure warning light stays on after starting the engine, stop the engine immediately and investigate the cause. Running the engine with low oil pressure will cause severe engine damage.

- The motorcycle is equipped with starter lockout switches. The switches prevent the electric starter from operating when the transmission is not in neutral with the sidestand down.

- If the sidestand is extended whilst the engine is running, and the transmission is not in neutral then the engine will stop irrespective of clutch position.

## Moving Off

Pull in the clutch lever and select first gear. Open the throttle a little and let out the clutch lever slowly. As the clutch starts to engage, open the throttle a little more, allowing enough engine speed to avoid stalling.

## Changing Gears

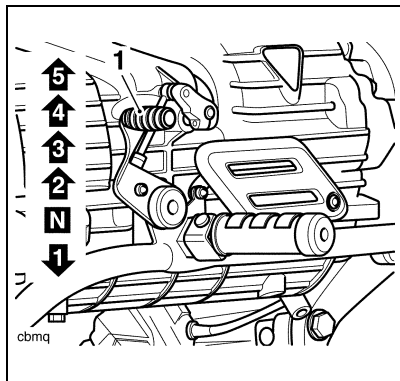

Close the throttle while pulling in the clutch lever. Change into the next higher or lower gear. Open the throttle part way, while releasing the clutch lever. Always use the clutch when changing gear.



## Warning

Take care to avoid opening the throttle too far in any of the lower gears as this can lead to the front wheel lifting from the ground (pulling a 'wheelie') and to the rear tyre breaking traction (wheel spin). Always open the throttle cautiously, particularly if you are unfamiliar with the motorcycle, as a 'wheelie' or loss of traction will cause loss of motorcycle control and an accident.

## NOTE

- The gear change mechanism is the 'positive stop' type. This means that, for each movement of the gear change pedal, you can only select each gear, one after the other, in ascending or descending order.



## Warning

Do not change to a lower gear at speeds that will cause excessive engine rpm (r/min). This can lock the rear wheel causing loss of control and an accident. Engine damage may also be caused. Changing down should be done such that low engine speeds will be ensured.

## Braking

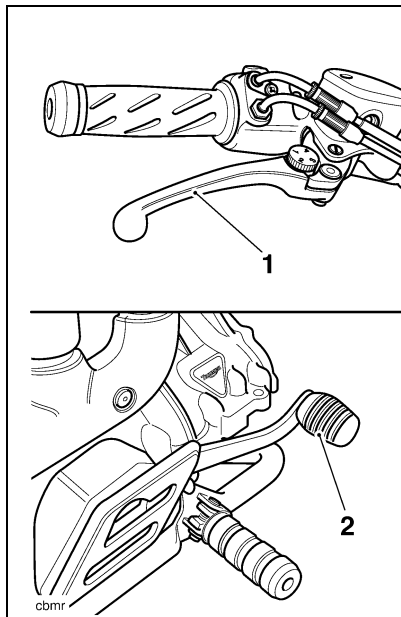

- 1 Front brake lever
- 2 Rear brake pedal



## Warning

### **WHEN BRAKING, OBSERVE THE FOLLOWING:**

Close the throttle completely, leaving the clutch engaged to allow the engine to help slow down the motorcycle.

Change down one gear at a time such that the transmission is in first gear when the motorcycle comes to a complete stop.

When stopping, always apply both brakes at the same time. Normally the front brake should be applied a little more than the rear.

Change down or fully disengage the clutch as necessary to keep the engine from stalling.

Never lock the brakes, as this may cause loss of control of the motorcycle and an accident.



## Warning

For emergency braking, disregard down changing, and concentrate on applying the front and rear brakes as hard as possible without skidding. Riders should practice emergency braking in a traffic-free area.

Triumph strongly recommends that all riders take a course of instruction, which includes advice on safe brake operation. Incorrect brake technique could result in loss of control and an accident.



## Warning

For your safety, always exercise extreme caution when braking, accelerating or turning as any incautious action can cause loss of control and an accident. Independent use of the front or rear brakes reduces overall braking performance. Extreme braking may cause either wheel to lock, reducing control of the motorcycle and causing an accident.

When possible, reduce speed or brake before entering a turn as closing the throttle or braking in mid-turn may cause wheel slip leading to loss of control and an accident.

When riding in wet or rainy conditions, or on loose surfaces, the ability to manoeuvre and stop will be reduced. All of your actions should be smooth under these conditions. Sudden acceleration, braking or turning may cause loss of control and an accident.



## Warning

When descending a long steep gradient, use engine braking by down changing and use the brakes intermittently. Continuous brake application can overheat the brakes and reduce their effectiveness.

Riding with your foot on the brake pedal or your hands on the brake lever may actuate the brake light, giving a false indication to other road users. It may also overheat the brake, reducing braking effectiveness.

Do not coast with the engine switched off, and do not tow the motorcycle. The transmission is pressure-lubricated only when the engine is running. Inadequate lubrication may cause damage or seizure of the transmission, which can lead to sudden loss of motorcycle control and an accident.

# How to Ride the Motorcycle

## Parking

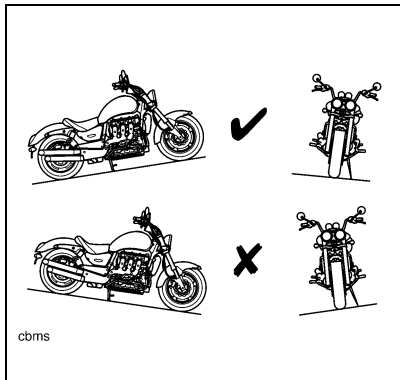

Select neutral and turn the ignition switch to the 'OFF' position.

Lock the steering to help prevent theft.

Always park on a firm, level surface to prevent the motorcycle from falling.

When parking on a hill, always park facing uphill to prevent the motorcycle from rolling off the stand. Engage first gear to prevent the motorcycle from moving.

On a lateral (sideways) incline, always park such that the incline naturally pushes the motorcycle towards the sidestand.

Do not park on a lateral (sideways) incline of greater than  $6^{\circ}$  and never park facing downhill.

## NOTE

- When parking near traffic at night, or when parking in a location where parking lights are required by law, leave the tail, licence plate and position lights on by turning the ignition switch to P (Park).

Do not leave the switch in the 'P' position for long periods-of-time as this will discharge the battery.



## Warning

Do not park on a soft or on a steeply inclined surface as parking under these conditions may cause the motorcycle to fall over.

Ensure that the stand is fully retracted before riding off.

Petrol is extremely flammable and can be explosive under certain conditions. If parking inside a garage or other structure, be sure it is well ventilated and the motorcycle is not close to any source of flame or sparks. This includes any appliance with a pilot light.

The engine and exhaust system will be hot after riding. **DO NOT** park where pedestrians and children are likely to touch the motorcycle as touching any of the hot parts may cause unprotected skin to become burnt.

## Considerations for High Speed Operation



## Warning

This Triumph motorcycle should be operated within the legal speed limits for the particular road travelled. Operating a motorcycle at high speeds can be potentially dangerous since the time available to react to given traffic situations is greatly reduced as road speed increases. Always reduce speed in consideration of weather and traffic conditions.



## Warning

Only operate this Triumph motorcycle at high speed in closed-course on-road competition or on closed course racetracks. High-speed operation should only then be attempted by riders who have been instructed in the techniques necessary for high speed riding and are familiar with the motorcycle's characteristics in all conditions.

High-speed operation in any other circumstances is dangerous and will lead to loss of motorcycle control and an accident.



## Warning

The handling characteristics of a motorcycle at high speed may vary from those you are familiar with at legal road speeds. Do not attempt high-speed operation unless you have received sufficient training and have the required skills as a serious accident may result from incorrect operation.



## Warning

The items listed are extremely important and must never be neglected. A problem, which may not be noticed at normal operating speeds, may be greatly exaggerated at high speeds.

## General

Ensure the motorcycle has been maintained according to the scheduled maintenance chart.

## Steering

Check that the handlebar turns smoothly without excessive free play or tight spots. Ensure that the control cables do not restrict the steering in any way.

## Luggage

Make certain that any luggage containers are closed, locked and securely fitted to the motorcycle.

## Brakes

Check that the front and rear brakes are functioning properly.

## Tyres

High-speed operation is hard on tyres, and tyres that are in good condition are crucial to riding safely. Examine their overall condition, inflate to the correct pressure (when the tyres are cold), and check the wheel balance. Securely fit the valve caps after checking tyre pressures. Observe the information given in the maintenance and specification sections on tyre checking and tyre safety.

## Fuel

Have sufficient fuel for the increased fuel consumption that will result from high-speed operation.



## Caution

In many countries, the exhaust system for this model is fitted with a catalytic converter to help reduce exhaust emission levels. The catalytic converter can be permanently damaged if the motorcycle is allowed to run out of fuel or if the fuel level is allowed to get very low. Always ensure you have adequate fuel for your journey.

## Electrical Equipment

Make certain that the headlight, rear/brake light, direction indicators, horn etc., all work properly.

## Miscellaneous

Visually check that all fixings are tight.

## Engine Oil

Make certain that the engine oil level is correct. Ensure that the correct grade and type of oil is used when topping-up.

## Final Drive Oil

Make certain that the final drive oil level is correct. Ensure that the correct grade and type of oil is used when topping-up.

## Coolant

Check that the coolant level is at the upper level line in the expansion tank. (Always check the level with the engine cold).

This page intentionally left blank

### ACCESSORIES AND LOADING

The addition of accessories and carriage of additional weight can affect the motorcycle's handling characteristics causing changes in stability and necessitating a reduction in speed. The following information has been prepared as a guide to the potential hazards of adding accessories to a motorcycle and carrying passengers and additional loads.



#### Warning

Incorrect loading may result in an unsafe riding condition leading to an accident.

Always ensure any loads carried are evenly distributed on both sides of the motorcycle. Ensure that the load is correctly secured such that it will not move around while the motorcycle is in motion.

Always check the load security regularly (though not while the motorcycle is in motion) and ensure that the load does not extend beyond the rear of the motorcycle.

Never exceed the maximum vehicle loading weight of 235 kg.

This maximum loading weight is made up from the combined weight of the rider, passenger, any accessories fitted and any load carried.



#### Warning

Do not install accessories or carry luggage that impairs the control of the motorcycle. Make sure that you have not adversely affected any lighting component, road clearance, banking capability (i.e. lean angle), control operation, wheel travel, front fork movement, visibility in any direction, or any other aspect of the motorcycle's operation.



### Warning

Never ride an accessory equipped motorcycle at speeds above the legal speed limit or at a speed inappropriate for the circumstances.

Speeds in excess of 130 km/h (80 mph) should not be attempted on an accessory equipped motorcycle even where the legal speed limit permits this.

The presence of accessories will cause changes in the stability and handling of the motorcycle.

Failure to allow for changes in motorcycle stability may lead to loss of control or an accident.

Remember that the 130km/h (80mph) absolute limit will be reduced by the fitting of non-approved accessories, incorrect loading, worn tyres, overall motorcycle condition and poor road or weather conditions.



### Warning

Only operate this Triumph motorcycle at high speed in closed-course on-road competition or on closed course racetracks. High-speed operation should only then be attempted by riders who have been instructed in the techniques necessary for high speed riding and are familiar with the motorcycle's characteristics in all conditions.

High-speed operation in any other circumstances is dangerous and will lead to loss of motorcycle control and an accident.



### Warning

This motorcycle must not be operated above the legal road speed limit except in authorised closed course conditions.



### Warning

Your passenger should be thoroughly familiar with the motorcycle's operation.

The passenger can cause loss of control of the motorcycle by incorrect positioning during cornering and sudden movements.

It is important that the passenger sits still while the motorcycle is in motion and does not interfere with the operation of the motorcycle.

If a passenger is carried, the rider should instruct the passenger to keep his or her feet on the passenger footrests and to firmly hold onto the seat strap or the rider's waist or hips.

The passenger should also be advised to lean with the rider when travelling around corners and not to lean unless the rider does so.

Do not carry animals on your motorcycle.



### Warning

The handling and braking capabilities of a motorcycle will be affected by the presence of a passenger. The rider must make allowances for these changes when operating the motorcycle with a passenger and should not attempt such operation unless trained to do so and without becoming familiar and comfortable with the changes in motorcycle operating characteristics that this brings about.

Motorcycle operation without making allowances for the presence of a passenger could lead to loss of motorcycle control and an accident.



### Warning

Never attempt to store any items between the frame and the fuel tank. This can restrict the steering and will cause loss of control leading to an accident.

Weight attached to the handlebar or front fork will increase the mass of the steering assembly and can result in loss of steering control leading to an accident.



### Warning

Do not carry a passenger unless he or she is tall enough to reach the footrests provided.

A passenger who is not tall enough to reach the footrests will be unable to sit securely on the motorcycle and may cause instability leading to loss of control and an accident.



### Warning

If the passenger seat is used to carry small objects, they must not exceed 5 kg in weight, must not impair control of the motorcycle, must be securely attached and must not extend beyond the rear or sides of the motorcycle.

Carriage of objects in excess of 5 kg in weight, that are insecure, impair control or extend beyond the rear or sides of the motorcycle may lead to loss of motorcycle control and an accident.

## MAINTENANCE AND ADJUSTMENT

### Table of Contents

Scheduled Maintenance .....	53
Engine Oil .....	56
Oil Level Inspection .....	56
Oil and Oil Filter Change .....	57
Disposal of Used Engine Oil and Oil Filters .....	59
Oil Specification and Grade .....	60
Cooling System .....	60
Corrosion Inhibitors .....	60
Coolant Level Inspection .....	61
Coolant Level Adjustment .....	61
Coolant Change .....	62
Radiator Hoses .....	62
Throttle Control .....	63
Inspection .....	64
Clutch .....	66
Inspection .....	66
Adjustment .....	66
Brakes .....	67
Brake Wear Inspection .....	67
Brake Pad Wear Compensation .....	67
Disc Brake Fluid .....	68
Brake Fluid Level Inspection and Adjustment .....	69
Brake Light Switches .....	70
Windscreen Cleaning (if fitted) .....	70
Steering/Wheel Bearings .....	71
Steering Inspection .....	71
Inspecting the Steering (headstock) Bearings for Free-Play .....	71
Wheel Bearings Inspection .....	72
Front Suspension .....	73
Front Fork Inspection .....	73

# Maintenance and Adjustment

---

Suspension Adjustment .....	73
Suggested Suspension Settings .....	74
Final Drive Unit .....	75
Final Drive Oil Level Adjustment .....	75
Tyres .....	76
Tyre Inflation Pressures .....	76
Tyre Wear .....	76
Minimum Recommended Tread Depth .....	77
Tyre Replacement .....	78
Battery .....	81
Battery Removal .....	81
Battery Disposal .....	82
Battery Maintenance .....	82
Battery Installation .....	83
Fuse Box .....	83
Fuse Identification .....	84
Headlights .....	85
Headlight Vertical Adjustment .....	85
Headlight Horizontal Adjustment .....	86
Headlight Bulb Replacement .....	86
Rear Light .....	88
Bulb Replacement .....	88
Indicator Lights .....	89
Bulb Replacement .....	89
Cleaning .....	89
Preparation for Washing .....	89
Where to be Careful .....	90
After Washing .....	90
Unpainted Aluminium Items .....	91
Cleaning of the Exhaust System .....	91
Washing .....	91
Drying .....	91
Protecting .....	92

## Scheduled Maintenance

To maintain the motorcycle in a safe and reliable condition, the maintenance and adjustments outlined in this section must be carried out as specified in the schedule of daily checks, and also in line with the scheduled maintenance chart. The information that follows describes the procedures to follow when carrying out the daily checks and some simple maintenance and adjustment items.



### Warning

In order to correctly carry out the maintenance items listed in the scheduled maintenance chart, special tools and specialist knowledge will be required. Only an authorised Triumph dealer will have this knowledge and equipment.

Since incorrect or neglected maintenance can lead to a dangerous riding condition, always have an authorised Triumph dealer carry out the scheduled maintenance of this motorcycle.



### Warning

All maintenance is vitally important and must not be neglected. Incorrect maintenance or adjustment may cause one or more parts of the motorcycle to malfunction. A malfunctioning motorcycle may lead to loss of control and an accident.

Weather, terrain and geographical location affects maintenance. The maintenance schedule should be adjusted to match the particular environment in which the vehicle is used and the demands of the individual owner.

Triumph Motorcycles cannot accept any responsibility for damage or injury resulting from incorrect maintenance or improper adjustment carried out by the owner.

Since incorrect or neglected maintenance can lead to a dangerous riding condition, always have an authorised Triumph dealer carry out the scheduled maintenance of this motorcycle.

# Maintenance and Adjustment

Operation Description	Odometer Reading in Miles (Kms) or time period, whichever comes first							
	Every	500 (800) 1 month	10,000 (16,000) 1 year	20,000 (3,2000) 2 years	30,000 (48,000) 3 years	40,000 (64,000) 4 years	50,000 (80,000) 5 years	60,000 (96,000) 6 years
Engine - check for leaks	Day	*	*	*	*	*	*	*
Engine oil - renew	-	*	*	*	*	*	*	*
Engine oil filter - renew	-	*	*	*	*	*	*	*
Valve clearances - check	-		*		*		*	
Air cleaner - renew	-			*		*		*
Engine ECM - check for stored DTC's	-	*	*	*	*	*	*	*
Spark plugs - check	-		*	*		*	*	
Spark plugs - renew	-				*			*
Throttle bodies - balance	-		*	*	*	*	*	*
Throttle cables - check/adjust	Day	*	*	*	*	*	*	*
Cooling system - check for leaks	-	*	*	*	*	*	*	*
Coolant level - check/adjust	Day	*	*		*		*	
Coolant - renew	-			*		*		*
Fuel system - check for leaks	Day	*	*	*	*	*	*	*
Lights, instruments & electrical systems - check	Day	*	*	*	*	*	*	*
Fuel filter - renew	-			*		*		*
Steering - check for free operation	Day	*	*	*	*	*	*	*
Headstock bearings - check/adjust	-	*	*	*	*	*	*	*
Headstock bearings - lubricate	-			*		*		*
Forks - check for leaks/smooth operation	Day	*	*	*	*	*	*	*
Fork oil - renew	-					*		
Brake fluid levels - check	Day	*	*	*	*	*	*	*
Brake fluid - renew		Every 2 years						

# Maintenance and Adjustment

Operation Description	Odometer Reading in Miles (Kms) or time period, whichever comes first							
	Every	500 (800) 1 month	10,000 (16,000) 1 year	20,000 (3,2000) 2 years	30,000 (48,000) 3 years	40,000 (64,000) 4 years	50,000 (80,000) 5 years	60,000 (96,000) 6 years
Brake pad wear - check	Day	*	*	*	*	*	*	*
Brake calipers - check for leaks and seizures	-	*	*	*	*	*	*	*
Brake master cylinders - check for oil leaks	-	*	*	*	*	*	*	*
Final drive - check for oil leaks	Day	*	*	*	*	*	*	*
Final drive oil - renew	-			*		*		*
Final drive oil - oil check	-	*	*		*		*	
Fasteners - inspect visually for security	Day	*	*	*	*	*	*	*
Wheels - inspect for damage	Day	*	*	*	*	*	*	*
Tyre wear/tyre damage - check	Day	*	*	*	*	*	*	*
Tyre pressures - check/adjust	Day	*	*	*	*	*	*	*
Clutch cable - check/adjust	Day	*	*	*	*	*	*	*
Stand - check operation	Day	*	*	*	*	*	*	*

## Engine Oil



In order for the engine, transmission, and clutch to function correctly, maintain the engine oil at the correct level, and change the oil and oil filter in accordance with scheduled maintenance requirements.



### Warning

Motorcycle operation with insufficient, deteriorated, or contaminated engine oil will cause accelerated engine wear and may result in engine or transmission seizure. Seizure of the engine or transmission may lead to sudden loss of control and an accident.

## Oil Level Inspection

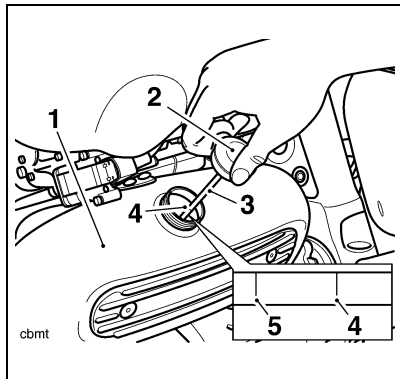

- 1 Oil tank
- 2 Oil tank cap
- 3 Dipstick
- 4 Maximum mark
- 5 Minimum mark



### Caution

Ensure no foreign matter or contamination enters the oil tank during an oil change or top-up. Contamination entering the oil tank may lead to engine damage

Stop engine.

Remove the filler cap/dipstick from the oil tank, wipe the dipstick clean and refit the filler cap, pushing it fully home.

## NOTE

- The actual level is indicated when the motorcycle is upright, (not on the side stand) and when the filler cap/dipstick has been pushed fully home.

Remove the filler cap/dipstick.

The maximum oil level is indicated by a mark on the filler cap/dipstick. When the oil level is correct, the indicated oil level must be between the maximum and minimum lines on the dipstick.

If the oil level is too low, add oil a little at a time until the correct level is reached.

Once the correct level is reached, fit the filler cap/dipstick.

## Oil and Oil Filter Change

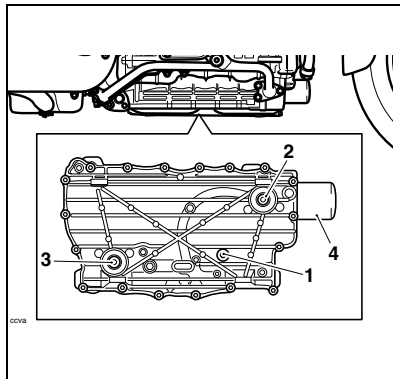

- 1 Oil tank drain plug
- 2 Front sump drain plug
- 3 Rear sump drain plug
- 4 Oil filter cover

The engine oil and filter must be replaced in accordance with scheduled maintenance requirements.

Because this motorcycle has a dry-sump lubrication system, the oil change procedure differs from those many will be familiar with. This is because the majority of the oil is contained in the oil tank on the left side of the engine, not in the sump. To change the engine oil and filter, follow the instructions below/over.



### Warning

Prolonged or repeated contact with engine oil can lead to skin dryness, irritation and dermatitis. In addition, used engine oil contains harmful contamination that can lead to skin cancer. Always wear suitable protective clothing and avoid skin contact with used oil.

Allow the engine to idle briefly, then stop the engine and secure the motorcycle in an upright position.

Place an oil drain pan beneath the engine.

Remove the oil tank drain plug from the bottom of the sump and allow the oil tank to drain.

### NOTE

- **Removal of the oil tank drain plug allows the oil to drain from the oil tank, not the sump. In order to drain the one or two litres of oil left in the sump, the front and rear sump plugs must also be removed.**

Incorporating a new washer, refit the oil tank drain plug, tightening it to **25 Nm**.

Position the oil drain pan towards the front of the engine, remove the front sump drain plug and allow the oil to

drain. This will drain the oil remaining in the front part of the sump.

Incorporating a new washer, refit the front sump plug, tightening it to **25 Nm**.

Position the oil drain pan towards the rear of the engine, remove the rear sump plug and allow the remaining oil to drain. This will drain any oil remaining in the rear part of the sump.

Incorporating a new washer, refit the rear sump plug. Tighten to **25 Nm**.



### Warning

The oil may be hot to the touch. Avoid contact with the hot oil by wearing suitable protective clothing, gloves, eye protection, etc. Contact with hot oil may cause the skin to be scalded or burned.

Remove the oil filter cover by pulling it gently towards the front of the motorcycle.

Position the oil drain pan beneath the oil filter.

Unscrew and remove the oil filter using Triumph service tool T3880312. Dispose of the old filter in an environmentally friendly way.

Apply a thin smear of clean engine oil to the sealing ring of the new oil filter. Fit the oil filter and tighten to **10 Nm**.

Fill the oil tank to the maximum mark with a 10W/40 or 15W/50 semi or fully synthetic motorcycle engine oil that meets specification API SH (or higher) AND JASO MA.

Start the engine and allow it to idle for a minimum of 30 seconds.

Turn off the ignition, check the oil level using the method previously described, and top up to between the minimum and maximum level lines on the dipstick.

## NOTE

- **When the engine is first started after an oil and filter change, at least 1 to 1.5 litres of oil will be required to top-up the oil tank to the correct level.**



## Caution

Raising the engine speed above idle, before the oil reaches all parts of the engine can cause engine damage or seizure. Only raise engine speed after running the engine for a few seconds to allow the oil to circulate fully.



## Caution

If the engine oil pressure is too low, the low oil pressure warning light will illuminate. If this light stays on when the engine is running, stop the engine immediately and investigate the cause. Running the engine with low oil pressure will cause engine damage.

Ensure that the low oil pressure warning light extinguishes shortly after starting.

## Disposal of Used Engine Oil and Oil Filters

To protect the environment, do not pour oil on the ground, down sewers or drains, or into watercourses. Do not place used oil filters in with general waste. If in doubt contact your local authority.

# Maintenance and Adjustment

## Oil Specification and Grade

Triumph high performance fuel injected engines are designed to use 10W/40 or 15W/50 semi or fully synthetic motorcycle engine oil that meets specification API SH (or higher) AND JASO MA.

Do not add any chemical additives to the engine oil. The engine oil also lubricates the clutch and any additives could cause the clutch to slip.

Do not use mineral, vegetable, non-detergent oil, castor based oils or any oil not conforming to the required specification. The use of these oils may cause instant, severe engine damage.

## Cooling System



cbob

To ensure efficient engine cooling, check the coolant level each day before riding the motorcycle, and top up the coolant if the level is low.

## Corrosion Inhibitors

To protect the cooling system from corrosion, the use of corrosion

inhibitor chemicals in the coolant is essential.

If coolant containing a corrosion inhibitor is not used, the cooling system will accumulate rust and scale in the water jacket and radiator. This will block the coolant passages, and considerably reduce the efficiency of the cooling system.



## Warning

Use coolant mixture containing corrosion inhibitors and anti-freeze suitable for aluminium engines and radiators. Always use the anti-freeze in accordance with the instructions of the manufacturer.

Coolant mixture that contains anti-freeze and corrosion inhibitors contains toxic chemicals that are harmful to the human body. Never swallow anti-freeze or any of the motorcycle coolant.

## Coolant Level Inspection

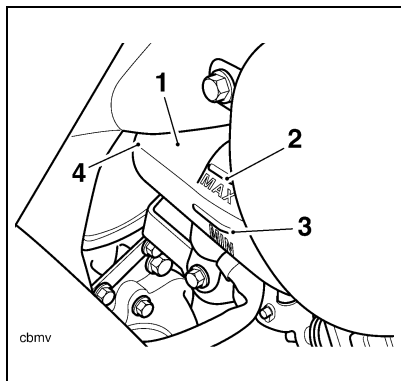

- 1 Expansion tank
- 2 MAX mark
- 3 MIN mark
- 4 Fluid level

Position the motorcycle on level ground and in an upright position.

The coolant level within the expansion tank can be inspected without removing any covers.

Check the coolant level in the expansion tank. The coolant level must be between the 'MAX' (upper line) and 'MIN' (lower line) marks. If the coolant is below the minimum level, the coolant level must be adjusted.

## Coolant Level Adjustment



### Warning

Do not remove the expansion tank or radiator pressure cap when the engine is hot. When the engine is hot, the coolant inside the expansion tank will be hot and also under pressure. Contact with this hot, pressurised coolant will cause scalds and skin damage.

Allow the engine to cool.

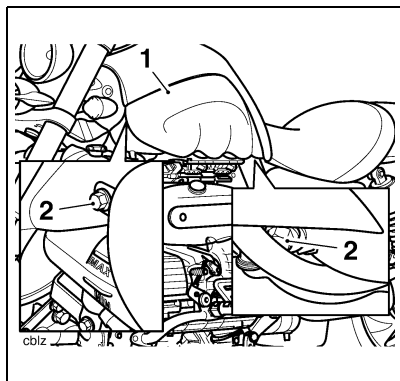

- 1 Intake cover
- 2 Intake cover screws

Remove the intake cover as follows: Release the two screws from its front and rear edges and then slide it downwards to release it from two support studs in its centre.

# Maintenance and Adjustment

Remove the cap from the expansion tank, and add coolant mixture through the filler opening until the level reaches the 'MAX' mark. Refit the cap.

## NOTE

- **If the coolant level is being checked because the coolant has overheated, also check the level in the radiator and top-up if necessary.**

In an emergency, water alone can be added to the cooling system. However, the coolant must be returned to the correct mixture ratio as soon as possible.

Refit the intake cover as follows: Align the cover to the centre studs and ease it into place. Fit and tighten the two screws to **9 Nm**.

## Coolant Change

Have the coolant changed by an authorised Triumph dealer in accordance with scheduled maintenance requirements.

## Radiator Hoses

Check the radiator hoses for cracks or deterioration, and hose clips for tightness in accordance with scheduled maintenance requirements. Have your authorised

Triumph dealer replace any defective items.



## Caution

A year-round type of antifreeze is installed in the cooling system when the motorcycle leaves the factory. It is coloured blue, contains a 50% solution of ethylene glycol, and has a freezing point of  $-35^{\circ}\text{C}$  ( $-31^{\circ}\text{F}$ ).

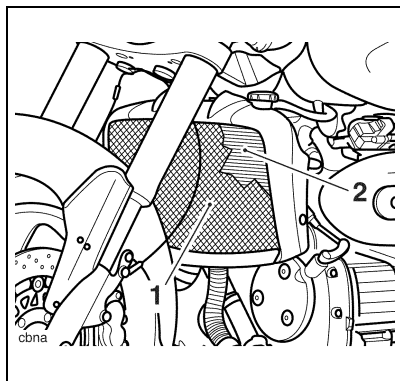

- 1 Radiator grille
- 2 Radiator fins

Check the radiator grille and fins for obstructions by insects, leaves or mud. Clean off any obstructions with a stream of low-pressure water.



## Warning

The fan operates automatically when the engine is running. Always keep hands and clothing away from the fan as contact with the rotating fan can cause injury.



## Caution

Using high-pressure water sprays, such as from a car wash facility or household pressure washer, can damage the radiator fins, cause leaks and impair the radiator's efficiency.

Do not obstruct or deflect airflow through the radiator by installing unauthorised accessories, either in front of the radiator or behind the cooling fan. Interference with the radiator airflow can cause overheating, potentially resulting in engine damage.

## Throttle Control

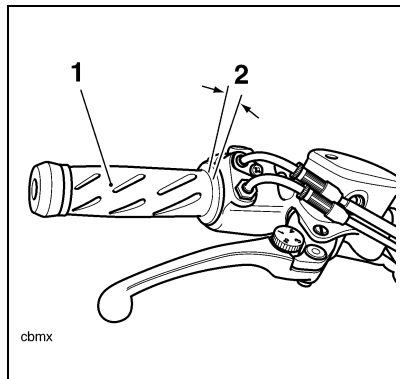

cbmx

- 1 Throttle grip
- 2 2-3 mm



## Warning

The throttle grip controls the throttle valves in the throttle bodies. If the throttle cables are incorrectly adjusted, either too tight or too loose, the throttle may be difficult to control and performance will be adversely affected.

Check the throttle grip free-play in accordance with scheduled maintenance requirements and make adjustments as necessary.

*/continued*



## Warning

*/continued*

Always be alert for changes in the 'feel' of the throttle and have the throttle system checked by an authorised Triumph dealer if any changes are detected. Changes can be due to wear in the mechanism, which could lead to a sticking throttle.

An incorrectly adjusted, sticking or stuck throttle will lead to loss of motorcycle control and an accident.

## Inspection

Check that the throttle opens smoothly, without undue force and that it closes without sticking. Have your authorised Triumph dealer check the throttle system if a problem is detected or any doubt exists.

Check that there is 2-3 mm of throttle grip free-play when lightly turning the throttle grip back and forth.

If there is an incorrect amount of free-play, Triumph recommends that you have adjustments made by your authorised Triumph dealer. However, in an emergency, throttle adjustment may be made as follows:



## Warning

Use of the motorcycle with incorrectly adjusted, incorrectly routed, sticking or damaged throttle cables will interfere with the throttle function resulting in loss of motorcycle control and an accident. To avoid incorrect adjustment, incorrect routing, or continued use of a sticking or damaged throttle, always have your throttle checked and adjusted by your authorised Triumph dealer.

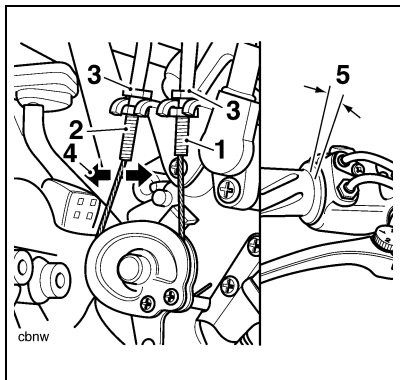

- 1 Opening cable adjuster
- 2 Closing cable adjuster
- 3 Locknuts
- 4 Closing cable - free play measurement point
- 5 Opening cable – free play measurement point

Remove the seat.

Disconnect the battery, negative (black) lead first.

Remove the intake cover as described in the cooling section.

Release the locknut on the 'opening' cable adjuster.

Rotate the 'opening' cable adjuster at the twist grip end such that it has an equal amount of adjustment in each direction.

Rotate the 'opening' cable adjuster at the throttle body end of the cable to give 2-3 mm of play at the twist grip. Tighten the locknut.

Make any minor adjustments as necessary to give 2-3 mm of play using the adjuster near the twist grip end of the cable. Tighten the locknut.

With the throttle fully closed, ensure that there is 2-3mm of free play in the 'closing' cable at the throttle cam attached to the throttle bodies. If necessary, adjust in the same way as the 'opening' cable until 2-3 mm of play is present.



## Warning

Ensure that all the adjuster locknuts of both cables are tightened, as a loose locknut could result in a sticking throttle.

An incorrectly adjusted, sticking or stuck throttle can lead to loss of motorcycle control and an accident.

Refit the intake cover, tightening the screws to **9 Nm**.

Reconnect the battery, positive (red) lead first.

Refit the seat.

Check that the throttle opens smoothly, without undue force and that it closes without sticking.

Ride carefully to your nearest authorised Triumph dealer and have him check the throttle system thoroughly before riding again.

## Clutch

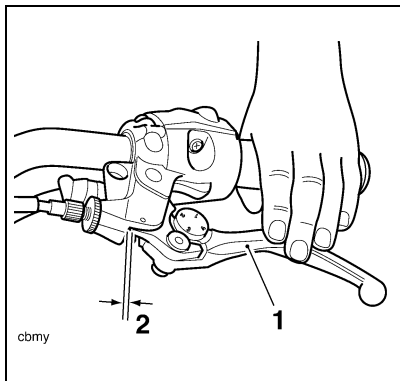

- 1 Clutch lever
- 2 2-3 mm

The motorcycle is equipped with a cable-operated clutch.

If the clutch lever has excessive free-play, the clutch may not disengage fully. This will cause difficulty in changing gear and selecting neutral. This may cause the engine to stall and make the motorcycle difficult to control. Conversely, if the clutch lever has insufficient free-play the clutch may not engage fully, causing the clutch to slip, which will reduce performance and cause premature clutch wear.

Clutch lever free-play must be checked in accordance with scheduled maintenance requirements.

## Inspection

Check that there is 2-3 mm clutch lever free-play at the lever.

If there is an incorrect amount of free-play, adjustments must be made.

## Adjustment

Loosen the knurled locknut at the lever end of the clutch cable and turn the adjuster sleeve until the correct amount of clutch lever free-play is achieved.

Tighten the knurled locknut against the clutch lever assembly.

If correct adjustment cannot be made using the lever adjuster, use the cable adjuster at the lower end of the cable.

Loosen the adjuster locknut.

Turn the outer cable adjuster to give 2-3 mm of free-play at the clutch lever.

Tighten the locknut.

## Brakes

### Brake Wear Inspection

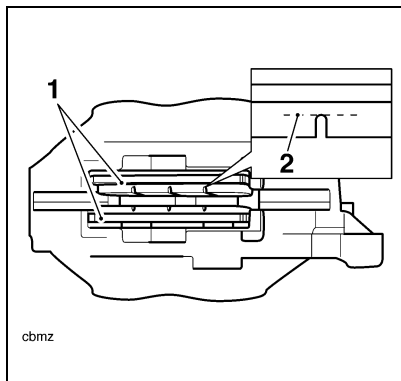

- 1 Brake pads
- 2 Minimum thickness line

Brake pads must be inspected in accordance with scheduled maintenance requirements and replaced if worn to, or beyond the minimum service thickness.

If the lining thickness of any pad (front or rear brakes) is less than 1.5 mm (0.06 in), that is, if the pad has worn down to the bottom of the grooves, replace all the pads on the wheel.



### Warning

Brake pads must always be replaced as a wheel set. At the front, where two callipers are fitted on the same wheel, replace all the brake pads in both callipers.

Replacing individual pads will reduce braking efficiency and may cause an accident.

After replacement brake pads have been fitted, ride with extreme caution until the new pads have 'broken in'.

### Brake Pad Wear Compensation

Disc and brake pad wear is automatically compensated for and has no effect on the brake lever or pedal action. There are no parts that require adjustment on the front and rear brakes.



## Warning

If the brake lever or pedal feels soft when it is applied, or if the lever/pedal travel becomes excessive, there may be air in the brake pipes and hoses or the brakes may be defective.

It is dangerous to operate the motorcycle under such conditions and your authorised Triumph dealer must rectify the fault before riding.

Riding with defective brakes may lead to loss of motorcycle control and an accident.

## Disc Brake Fluid

Inspect the level of brake fluid in both reservoirs and change the brake fluid in accordance with scheduled maintenance requirements. Use only DOT 4 fluid as recommended in the specification section. The brake fluid must also be changed if it becomes, or is suspected of having become contaminated with moisture or any other contaminants.



## Warning

Brake fluid is hygroscopic which means it will absorb moisture from the air.

Any absorbed moisture will greatly reduce the boiling point of the brake fluid causing a reduction in braking efficiency.

Because of this, always replace brake fluid in accordance with scheduled maintenance requirements.

Always use new brake fluid from a sealed container and never use fluid from an unsealed container or from one which has been previously opened.

Do not mix different brands or grades of brake fluid.

Check for fluid leakage around brake fittings, seals and joints and also check the brake hoses for splits, deterioration and damage.

Always rectify any faults before riding.

Failure to observe and act upon any of these items may cause a dangerous riding condition leading to loss of control and an accident.

## Brake Fluid Level Inspection and Adjustment

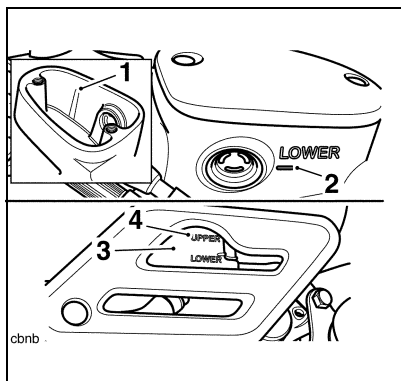

- 1 Front brake fluid reservoir, upper level line
- 2 Lower level line
- 3 Rear brake fluid reservoir, lower level line
- 4 Upper level line

The brake fluid level in the reservoirs must be kept between the upper and lower level lines (reservoir held horizontal).

Release the screws securing the front brake reservoir cover, then remove the cover.

Fill the reservoir to the upper level line using new DOT 4 fluid from a sealed container.

Refit the reservoir cover ensuring that the diaphragm seal is correctly fitted. Tighten the screws to **2 Nm**.

Remove the screws securing the right hand heel guard to the footrest bar then lift the guard out of the way.

Remove the screws securing the rear brake fluid reservoir cover, then remove the cover.

Fill the reservoir to the upper level line using new DOT 4 fluid from a sealed container.

Refit the reservoir cover ensuring that the diaphragm seal is correctly fitted. Tighten the screws to **2 Nm**.

Refit the heel guard and tighten the screws to **9 Nm**.



## Warning

If there has been an appreciable drop in the level of the fluid in either fluid reservoir, consult your authorised Triumph dealer for advice before riding. Riding with depleted brake fluid levels, or with a brake fluid leak is dangerous and will cause reduced brake performance potentially leading to loss of motorcycle control and an accident.

## Brake Light Switches

The brake light is activated independently by either the front or rear brake. If, with the ignition in the 'ON' position, the brake light does not work when the front brake lever is pulled or the rear brake pedal is pressed, ask your authorised Triumph dealer to investigate and rectify the fault.



### Warning

Riding the motorcycle with defective brake lights is illegal and dangerous.

An accident causing injury to the rider and other road users may result from use of a motorcycle with defective brake lights.

## Windscreen Cleaning (if fitted)

Always clean the windscreen with clean water and a soft cloth. Dry after cleaning with a soft, lint free cloth. Minor scratches can be removed using a commercial polishing compound suitable for plastic.

The windscreen must be replaced if scratches cannot be completely removed.



### Warning

Never attempt to clean the windscreen while the motorcycle is in motion as releasing the handlebars may cause loss of vehicle control and an accident.

Operation of the motorcycle with a damaged or scratched windscreen will reduce the rider's forward vision. Any such reduction in forward vision is dangerous and may lead to an accident causing injury or death.



### Caution

Corrosive chemicals such as battery electrolyte will damage the windscreen. Never allow corrosive chemicals to contact the windscreen.

## Steering/Wheel Bearings

### Steering Inspection

Lubricate and inspect the condition of the headstock (steering) bearings in accordance with scheduled maintenance requirements.

#### NOTE

- **Always inspect the wheel bearings at the same time as the steering bearings.**



### Warning

To prevent risk of injury from the motorcycle falling during the inspection, ensure that the motorcycle is stabilised and secured on a suitable support. Do not exert extreme force against each wheel or rock each wheel vigorously as this may cause the motorcycle to become unstable and cause injury by falling from its support.

Ensure that the position of the support block will not cause damage to the sump.

### Inspecting the Steering (headstock) Bearings for Free-Play

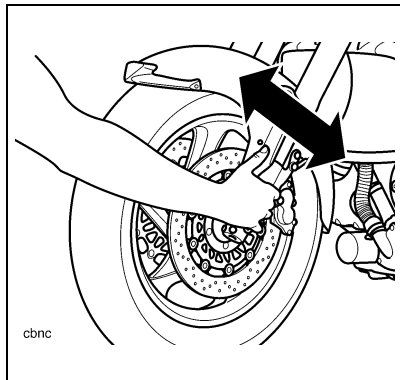

Position the motorcycle on level ground, in an upright position.

Raise the front wheel above the ground and support the motorcycle.

Standing at the front of the motorcycle, hold the lower end of the front forks and try to move them forward and backward.

If any free-play can be detected in the steering (headstock) bearings, ask your authorised Triumph dealer to inspect and rectify any faults before riding.

# Maintenance and Adjustment



## Warning

Riding the motorcycle with incorrectly adjusted or defective steering (headstock) bearings is dangerous and may cause loss of motorcycle control and an accident.

Remove the support and place the motorcycle on the side stand.

## Wheel Bearings Inspection

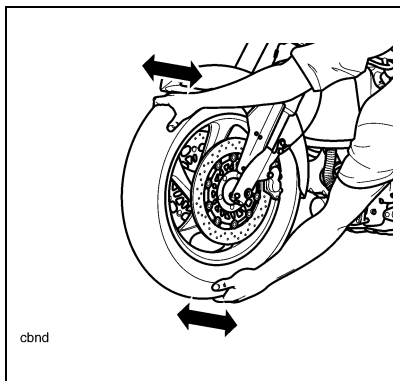

If the wheel bearings in the front or rear wheel allow play in the wheel hub, are noisy, or if the wheel does not turn smoothly, have your authorised Triumph dealer inspect the wheel bearings.

The wheel bearings must be inspected at the intervals specified in the scheduled maintenance chart.

Position the motorcycle on level ground, in an upright position.

Raise the front wheel above the ground and support the motorcycle.

Standing at the side of the motorcycle, gently rock the top of the front wheel from side to side.

If any free-play can be detected, ask your authorised Triumph dealer to inspect and rectify any faults before riding.

Reposition the lifting device and repeat the procedure for the rear wheel.



## Warning

Operation with worn or damaged front or rear wheel bearings is dangerous and may cause impaired handling and instability leading to an accident. If in doubt, have the motorcycle inspected by an authorised Triumph dealer before riding.

Remove the support and place the motorcycle on the side stand.

## Front Suspension

### Front Fork Inspection

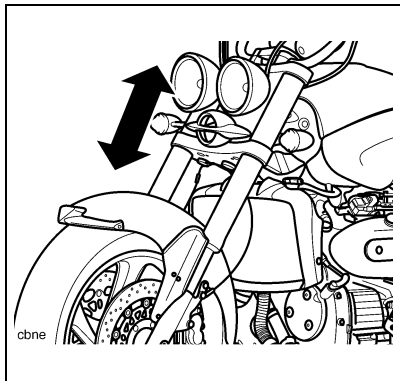

Examine each fork for any sign of damage, scratching of the slider surface, or for oil leaks.

If any damage or leakage is found consult an authorised Triumph dealer.

To check that the forks operate smoothly:

- Position the motorcycle on level ground.
- While holding the handlebars and applying the front brake, pump the forks up and down several times.
- If roughness or excessive stiffness is detected, consult your authorised Triumph dealer.



### Warning

Riding the motorcycle with defective or damaged suspension is dangerous and may lead to loss of control and an accident.



### Warning

Never attempt to dismantle any part of the suspension units, as all units contain pressurised oil. Skin and eye damage can result from contact with the pressurised oil.

## Suspension Adjustment

### Front Suspension

The front suspension is factory set and is not adjustable.

# Maintenance and Adjustment

## Rear Suspension

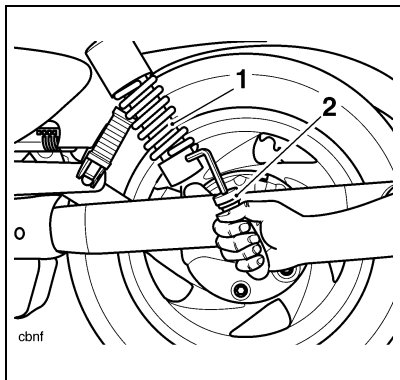

- 1 Rear suspension unit
- 2 Adjustment tool

The rear suspension is adjustable for pre-load only.

To change the rear suspension spring pre-load setting, insert the adjustment tool supplied in the tool kit into the hole provided in the adjuster ring.

Turn the adjuster ring clockwise to increase spring pre-load, and anti-clockwise to decrease spring pre-load. When delivered from the factory, the pre load adjuster will be set at position 1.



## Warning

Ensure that the adjusters are set to the same setting on both rear suspension units. Settings that vary from left to right may affect handling and stability resulting in loss of motorcycle control, and an accident.

## Suggested Suspension Settings

Adjuster settings are counted from position one with position one being with the adjuster turned fully anti-clockwise. There are five positions in total. Position one gives the minimum amount of spring pre-load.

Riding Condition	Suspension Preload Setting
Rider only	Position 1
Rider and passenger	Position 2
Rider, passenger and luggage	Position 5

## NOTE

- The details given in the table are to be used as a guide only where the rider and passenger each weigh 90 kg or less. Setting requirements should be increased for heavier riders and passengers and according to personal preferences.

## Final Drive Unit

Other than checking and changing the final drive oil level, the unit contains no user serviceable parts. If a fault occurs with the final drive unit, your Triumph dealer must replace the complete assembly.

Check the final drive unit for oil leaks in accordance with the scheduled maintenance chart.

## Final Drive Oil Level Adjustment

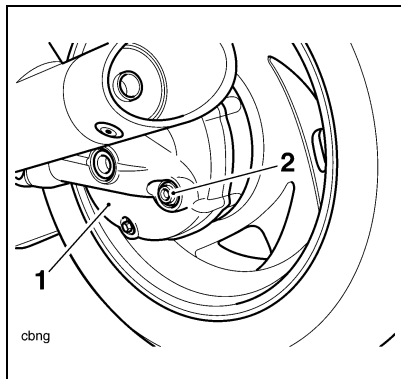

- 1 Final drive unit
- 2 Oil level/filler plug

To check the oil level in the final drive unit, remove the filler/level plug. Fill with Mobilube 1 SHC 75W/90 fully synthetic hypoid oil (or equivalent) until the level of oil inside the unit is level with the bottom of the filler. Refit the plug and tighten to **60 Nm**.



## Warning

Under no circumstances should the final drive unit be disassembled. Failure to observe the above warning could lead to a malfunction of the final drive unit causing lock-up of the rear wheel leading to loss of motorcycle control and an accident.

## Tyres

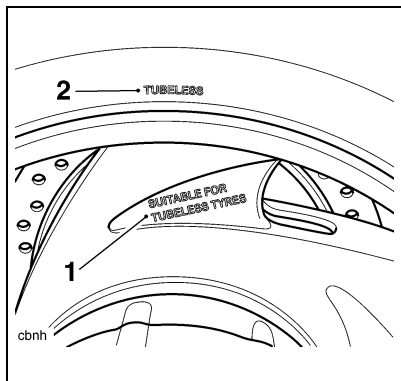

- 1 Wheel marking
- 2 Tyre marking

This motorcycle is equipped with tubeless tyres, valves and wheel rims. Use only tyres marked 'TUBELESS' and tubeless valves on rims marked 'SUITABLE FOR TUBELESS TYRES'.

### Tyre Inflation Pressures

Correct inflation pressure will provide maximum stability, rider comfort and tyre life. Always check tyre pressures before riding when the tyres are cold. Check tyre pressures daily and adjust if necessary. See the specification section for details of the correct inflation pressures.



## Warning

Incorrect tyre inflation will cause abnormal tread wear and instability problems that may lead to loss of control and an accident.

Under-inflation may result in the tyre slipping on, or coming off the rim. Over-inflation will cause instability and accelerated tread wear.

Both conditions are dangerous as they may cause loss of control leading to an accident.

### Tyre Wear

As the tyre tread wears down, the tyre becomes more susceptible to punctures and failure. It is estimated that 90% of all tyre problems occur during the last 10% of tread life (90% worn). It is, therefore, false economy and unsafe to use tyres until they are worn to their minimum.

## Minimum Recommended Tread Depth

In accordance with the periodic maintenance chart, measure the depth of the tread with a depth gauge, and replace any tyre that has worn to, or beyond the minimum allowable tread depth specified in the table below:

Under 130 km/h (80 mph)	2 mm (0.08 in)
Over 130 km/h (80 mph)	Rear 3 mm (0.12 in) Front 2 mm (0.08 in)



### Warning

This motorcycle must not be operated above the legal road speed limit except in authorised closed course conditions.



### Warning

Only operate this Triumph motorcycle at high speed in closed course on-road competition or on closed course race tracks. High speed operation should only then be attempted by riders who have been instructed in the techniques necessary for high speed riding and are familiar with the motorcycle's characteristics in all conditions. High speed operation in any other circumstances is dangerous and will lead to loss of motorcycle control and an accident.



## Warning

Operation with excessively worn tyres is hazardous and will adversely affect traction, stability and handling which may lead to loss of control and an accident.

When tubeless tyres become punctured, leakage is often very slow. Always inspect tyres very closely for punctures. Check the tyres for cuts, embedded nails or other sharp objects. Operation with punctured or damaged tyres will adversely affect motorcycle stability and handling which may lead to loss of control or an accident.

Check the rims for dents or deformation. Operation with damaged or defective wheels or tyres is dangerous and loss of motorcycle control or an accident could result.

Always consult your authorised Triumph dealer for tyre replacement, or for a safety inspection of the tyres.

## Tyre Replacement

All Triumph motorcycles are carefully and extensively tested in a range of riding conditions to ensure that the most effective tyre combinations are approved for use on each model. It is essential that approved tyres, fitted in approved combinations, are used when purchasing replacement tyres. The use of non-approved tyres, or approved tyres in non-approved combinations, may lead to motorcycle instability and an accident. See the specification section for details of approved tyre combinations. Always have tyres fitted and balanced by your authorised Triumph dealer who has the necessary training and skills to ensure safe, effective fitment.



## Warning

If a tyre sustains a puncture, the tyre must be replaced. Failure to replace a punctured tyre, or operation with a repaired tyre can lead to instability, loss of control or an accident.



### Warning

Do not install tube-type tyres on tubeless rims. The bead will not seat and the tyres could slip on the rims, causing rapid tyre deflation that may result in a loss of vehicle control and an accident. Never install an inner tube inside a tubeless tyre. This will cause friction inside the tyre and the resulting heat build-up may cause the tube to burst resulting in rapid tyre deflation, loss of vehicle control and an accident.



### Warning

If tyre damage is suspected, such as after striking the kerb, ask your authorised Triumph dealer to inspect the tyre both internally and externally. Remember, tyre damage may not always be visible from the outside. Operation of the motorcycle with damaged tyres could lead to loss of control and an accident.



### Warning

When replacement tyres are required, consult your authorised Triumph dealer who will arrange for the tyres to be selected, in a correct combination, from the approved list and fitted according to the tyre manufacturer's instructions.

When tyres are replaced, allow time for the tyres to seat to the rim (approximately 24 hours). During this seating period, ride cautiously as an incorrectly seated tyre could cause loss of control or an accident.

Initially, the new tyres will not produce the same handling characteristics as the worn tyres and the rider must allow adequate riding distance (approximately 100 miles) to become accustomed to the new handling characteristics.

24 hours after fitting, the tyre pressures must be checked and adjusted, and the tyres examined for correct seating. Rectification must be carried out as necessary.

The same checks and adjustments must also be carried out when 100 miles have been travelled after fitting.

*/continued*



### Warning

*/continued*

Use of a motorcycle with incorrectly seated tyres, incorrectly adjusted tyre pressures, or when not accustomed to its handling characteristics may lead to loss of control and an accident.



### Warning

Tyres that have been used on a rolling road dynamometer may become damaged. In some cases, the damage may not be visible on the external surface of the tyre. Tyres must be replaced after such use as continued use of a damaged tyre may lead to instability, loss of control and an accident.



### Warning

Accurate wheel balance is necessary for safe, stable handling of the motorcycle. Do not remove or change any wheel balance weights. Incorrect wheel balance may cause instability leading to loss of control and an accident.

When wheel balancing is required, such as after tyre replacement, see your authorised Triumph dealer.

Only use self-adhesive weights. Clip on weights may damage the wheel and tyre resulting in tyre deflation, loss of control and an accident.

## Battery



### Warning

Under some circumstances, the battery can give off explosive gases; keep sparks, flames and cigarettes away. Provide adequate ventilation when charging or using the battery in an enclosed space.

The battery contains sulphuric acid (electrolyte). Contact with skin or eyes may cause severe burns. Wear protective clothing and a face shield.

If electrolyte gets on your skin, flush with water immediately.

If electrolyte gets in your eyes, flush with water for at least 15 minutes and **SEEK MEDICAL ATTENTION IMMEDIATELY.**

If electrolyte is swallowed, drink large quantities of water and **SEEK MEDICAL ATTENTION IMMEDIATELY.**

**KEEP ELECTROLYTE OUT OF THE REACH OF CHILDREN.**



### Warning

The battery contains harmful materials. Always keep children away from the battery whether or not it is fitted in the motorcycle.

Do not attach jump leads to the battery, touch the battery cables together or reverse the polarity of the cables as any of these actions may cause a spark which would ignite battery gases causing a risk of personal injury.

### Battery Removal

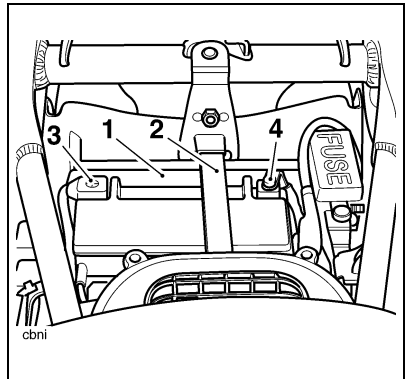

- 1 Battery
- 2 Battery strap
- 3 Positive (red) terminal
- 4 Negative terminal

Remove the seat.

# Maintenance and Adjustment

---

Lift up the tool box at its front edge and pivot it towards the rear of the motorcycle.

Remove the battery strap.

Disconnect the battery leads, negative (black) lead first.

Take the battery out of the case.



## Warning

Ensure that the battery terminals do not touch the motorcycle frame as this may cause a short circuit or spark, which would ignite battery gases causing a risk of personal injury.

## Battery Disposal

Should the battery ever require replacement, the original battery must be handed to a recycling agent who will ensure that the dangerous substances from which the battery is manufactured do not pollute the environment.

## Battery Maintenance

Clean the battery using a clean, dry, cloth. Be sure that the cable connections are clean.



## Warning

The battery electrolyte is corrosive and poisonous and will cause damage to unprotected skin. Never swallow battery electrolyte or allow it to come into contact with the skin. To prevent injury, always wear eye and skin protection when handling the battery.

The battery is a sealed type and will not require any maintenance other than routine recharging, such as during storage.

It is not possible to adjust the electrolyte level in the battery.

## Battery Installation



### Warning

Ensure that the battery terminals do not touch the motorcycle frame as this may cause a short circuit or spark, which would ignite battery gases causing a risk of personal injury.

Place the battery in the battery case.

Reconnect the battery, positive (red) lead first.

Apply a light coat of grease to the terminals to prevent corrosion.

Cover the positive terminal with the protective cap.

Refit the battery strap.

Lower the tool kit tray into place.

Refit the seat.

## Fuse Box

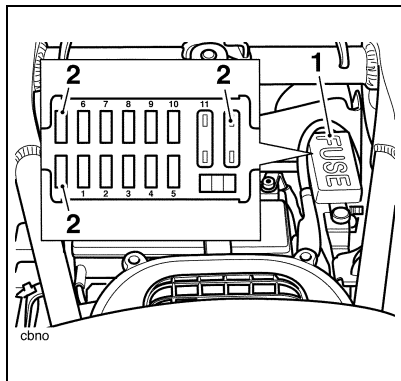

- 1 Fuse box
- 2 Spare fuses

### NOTE

- **Numbers shown in the diagram correspond to the fuse position numbers in the table overleaf.**

The fuse box is located beneath the rider's seat.

To allow access to the fuse box, the rider's seat must be removed.



## Warning

Always replace blown fuses with new ones of the correct rating (as specified on the fuse box cover) and never use a fuse of higher rating. Use of an incorrect fuse could lead to an electrical problem, resulting in motorcycle damage, loss of motorcycle control and an accident.

## Fuse Identification

A blown fuse is indicated when all of the systems protected by that fuse become inoperative. When checking for a blown fuse, use the table below to establish which fuse has blown.

Circuit Protected	Rating (Amps)	Position
Accessory lights	15	1
Ignition switch main feed	30	2
Accessory socket, instrument memory, heated grips, clock	10	3
Alarm, diagnostic connector, indicators, brake lights	15	4
Instruments, fuel pump relay, starter relay, main power relay, fall detection switch	10	5
Engine management system	20	6
Cooling fan	15	7
Instrument illumination, position lights	5	8
Upper and lower headlight beams, starter solenoid	20	9
Position lights	5	10
Main fuse	30	11

## Headlights



### Warning

Adjust road speed to suit the visibility and weather conditions in which the motorcycle is being operated.

Ensure that the beams are adjusted to illuminate the road surface sufficiently far ahead without dazzling oncoming traffic. An incorrectly adjusted headlight may impair visibility causing an accident.



### Warning

Never attempt to adjust a headlamp beam when the motorcycle is in motion.

Any attempt to adjust a headlamp beam when the motorcycle is in motion may result in loss of control and an accident.

### NOTE

- **The vertical beams of the left and right hand headlights can only be adjusted together. Independent adjustment is not possible.**

## Headlight Vertical Adjustment

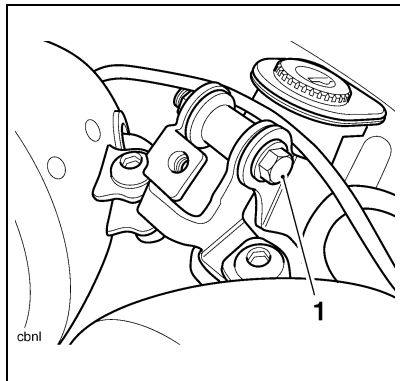

1 Vertical beam adjuster

Switch the headlight dipped beam on. Remove the adjuster cover.

Slacken the clamp bolt sufficient to allow restricted movement of the headlights.

Adjust the position of the headlights to give the required beam setting.

Tighten the clamp bolt to 15 Nm.

Re-check the headlight beam settings.

Switch the headlights off when both beam settings are satisfactorily set.

# Maintenance and Adjustment

## Headlight Horizontal Adjustment

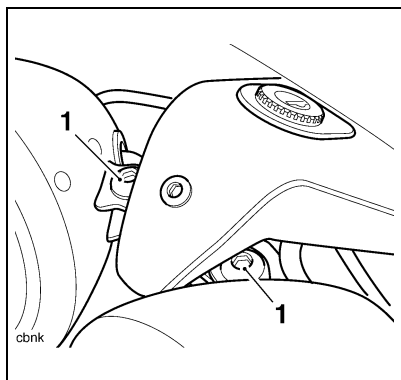

1 Horizontal beam adjusters

The horizontal beams of both headlights can be adjusted individually. The same procedure is used to adjust either headlight.

Switch the headlight dipped beam on.

Slacken the headlight bowl fixing.

Adjust the horizontal position of the headlight to give the required beam setting.

Tighten the fixing to 15 Nm.

Repeat for the second headlight.

Re-check the headlight beam settings.

Switch the headlight off when both beams are satisfactorily set.

## Headlight Bulb Replacement

It is necessary to remove the headlight from the headlight bowl to gain access to the bulbs.

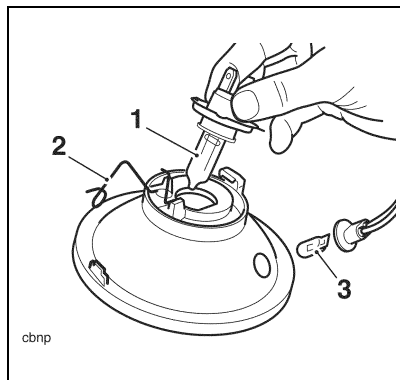

- 1 Headlight bulb
- 2 Bulb clip
- 3 Position light bulb



## Warning

The bulbs become hot during use. Always allow sufficient time for the bulbs to cool before handling. Avoid touching the glass part of the bulb. If the glass is touched or gets dirty, clean with alcohol before re-use.

Remove the front seat.

Disconnect the battery, negative (black) lead first.

Undo the fixing securing the headlight clamp to the headlight body.

Support the headlight while removing the clamp.

Remove the headlight from its bowl while supporting it to prevent the cables from being over extended.

Disconnect the multi-pin electrical connector from the headlight bulb and remove the rubber cover.

Detach the wire retainer from its clip (do not remove the screw) then remove the bulb from the light unit.

To remove the position light bulb:

Without pulling on the wires, ease the bulb holder from its socket. The bulb is removed from its holder by pulling gently upwards.

Installation for both bulbs is the reverse of the removal procedure. Tighten the headlight clamp to 4 Nm.



### Caution

When reconnecting the battery, connect the positive (red) lead first.



### Warning

Do not reconnect the battery until the assembly process has been completed. Premature battery reconnection could result in ignition of the battery gases causing risk of injury.

## Rear Light

### Bulb Replacement

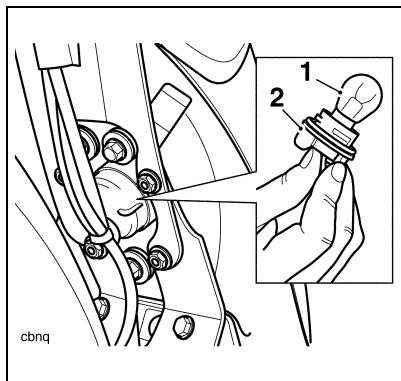

- 1 Rear light bulb
- 2 Bulb holder

Rotate the bulb holder anti-clockwise to release it from the lamp body.

To remove the bulb from the holder, gently pull on the bulb until it is released.

Installation for the bulb is the reverse of the removal procedure.



### Caution

When reconnecting the battery, connect the positive (red) lead first.



### Warning

The bulb becomes hot during use. Always allow sufficient time for the bulb to cool before handling. Avoid touching the glass part of the bulb. If the glass is touched or gets dirty, clean with alcohol before re-use.

Remove the front seat.

Disconnect the battery, negative (black) lead first.

The rear light bulb holder can be located underneath the rear mudguard.

## Indicator Lights

### Bulb Replacement

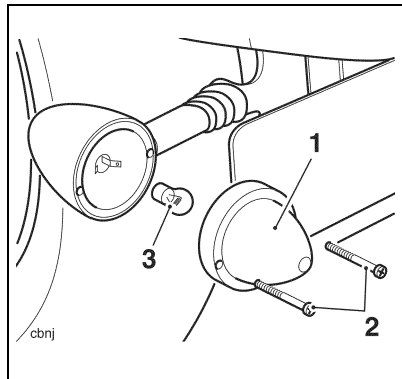

- 1 Lens
- 2 Lens screw
- 3 Bulb

The lens on each indicator light is held in place by two screws.

Release the screws and remove the lens to gain access to the bulb for replacement.

## Cleaning

Frequent, regular cleaning is an essential part of the maintenance of your motorcycle. If regularly cleaned, the appearance will be preserved for many years. Cleaning with warm water containing an automotive cleaner is essential at all times but particularly so after exposure to sea breezes, sea water, dusty or muddy roads and in winter when roads are treated for ice and snow.

Although, under the terms of your motorcycle warranty, cover is provided against the corrosion of certain items, the owner is expected to observe this reasonable advice which will safeguard against corrosion and enhance the appearance of the motorcycle. Do not use household detergent, as the use of such products will lead to premature corrosion.

### Preparation for Washing

Before washing, precautions must be taken to keep water off the following places.

Rear opening of the mufflers: Cover with a plastic bag secured with rubber bands.

Clutch and brake levers, switch housings on the handlebar: Cover with plastic bags.

# Maintenance and Adjustment

Ignition switch: Cover the keyhole with tape.

## Where to be Careful

Avoid spraying water with any great force near the following places:

- Instruments.
- Brake cylinders and brake callipers.
- Under the fuel tank.
- Headstock bearings.



### Caution

Do not spray any water at all under the rider's seat. The rider's seat has the engine's air intake ducts fitted to its base and any water sprayed in this area could enter the airbox and engine, causing damage to both items.



### Caution

Use of high-pressure spray washers is not recommended. When using pressure washers, water may be forced into bearings and other components causing premature wear from corrosion and loss of lubrication.

## NOTE

- **Use of soaps that contain high levels of alkaline will leave a residue on painted surfaces, and may also cause water spotting. Always use a low alkaline soap to aid the cleaning process.**

## After Washing

Remove the plastic bags and tape, and clear the air intakes.

Lubricate the pivots, bolts and nuts.

Test the brakes before motorcycle operation.

Start the engine and run it for 5 minutes. Ensure adequate ventilation for the exhaust fumes.

Use a dry cloth to absorb water residue. Do not allow water to stand on the machine as this will lead to corrosion.



### Warning

Never wax or lubricate the brake discs. Loss of braking power and an accident could result. Clean the disc with a proprietary brand of oil free brake disc cleaner.

## Unpainted Aluminium Items

Items such as brake and clutch levers must be correctly cleaned to preserve their appearance.

Use a proprietary brand of aluminium cleaner which does not contain abrasive or caustic elements.

Clean aluminium items regularly, in particular after use in inclement weather, where the components must be hand washed and dried each time the machine is used.

Warranty claims due to inadequate maintenance will not be allowed.

## Cleaning of the Exhaust System

All parts of the exhaust system of your motorcycle must be cleaned regularly to avoid a deterioration of its appearance. These instructions can be applied to chrome, brushed stainless steel and carbon fibre components alike.

### NOTE

- **The exhaust system must be cool before washing to prevent water spotting.**

## Washing

Prepare a mixture of water and mild soap. Do not use a high alkaline content soap as commonly found at commercial car washes because it leaves a residue.

Wash the exhaust system with a soft cloth. Do not use an abrasive scouring pad or steel wool. They will damage the finish.

Rinse the exhaust system thoroughly.

Ensure no soap or water enters the mufflers.

## Drying

Dry the exhaust system as far as possible with a soft cloth. Do not run the engine to dry the system or spotting will occur.

## Maintenance and Adjustment

---

### Protecting

When the exhaust system is dry, rub 'Motorex 645 Clean And Protect' into the surface.

It is recommended that regular protection be applied to the system as this will both protect and enhance the system's appearance.



### Caution

The use of silicone products such as WD40 will cause discolouration of the chrome and must not be used. Similarly, the use of abrasive cleaners such as Solvol Autosol will damage the system and must not be used.

## STORAGE

### Preparation for Storage

Clean the entire vehicle thoroughly.

Empty the fuel from the fuel tank into a secure container.



### Warning

Petrol is extremely flammable and can be explosive under certain conditions. Turn the ignition switch OFF. Do not smoke. Make sure the area is well ventilated and free from any source of flame or sparks; this includes any appliance with a pilot light.

Remove one of the spark plugs from each cylinder and put several drops (5 ml) of engine oil into each cylinder. Push the starter button for a few seconds to coat the cylinder walls with oil, and install the spark plugs.

Reduce the tyre pressures by about 20%.

Set the motorcycle on a box or stand so that both wheels are raised off the ground. (If this cannot be done, put boards under the front and rear wheels to keep dampness away from the tyres).

Spray oil on all unpainted metal surfaces to prevent rusting. Prevent

oil from getting on rubber parts, brake discs or in the brake callipers.

Lubricate the control cables.

Remove the battery, and store it where it will not be exposed to direct sunlight, moisture, or freezing temperatures. During storage it should be given a slow charge (one ampere or less) about once a month. Keep the battery well charged during cold weather so that the electrolyte does not freeze and crack the battery. The more discharged the battery becomes, the more easily it freezes.

Tie plastic bags over the exhaust pipes to prevent moisture from entering.

Put a cover over the motorcycle to keep dust and dirt from collecting on it.

## Preparation after Storage

Charge the battery if necessary, and install it in the motorcycle.

Fill the fuel tank with fuel.

Change the engine oil and filter.

Check all the points listed in the daily safety checks section.

Before starting the engine, remove one of the spark plugs from each cylinder.

Put side stand down.

Crank the engine on the starter motor several times until the oil pressure light goes out.

Replace spark plugs and start engine.

Check brakes and operation.

# SPECIFICATIONS

## Specifications Rocket III

### Dimensions

Main motorcycle dimensions are shown in the diagram below.

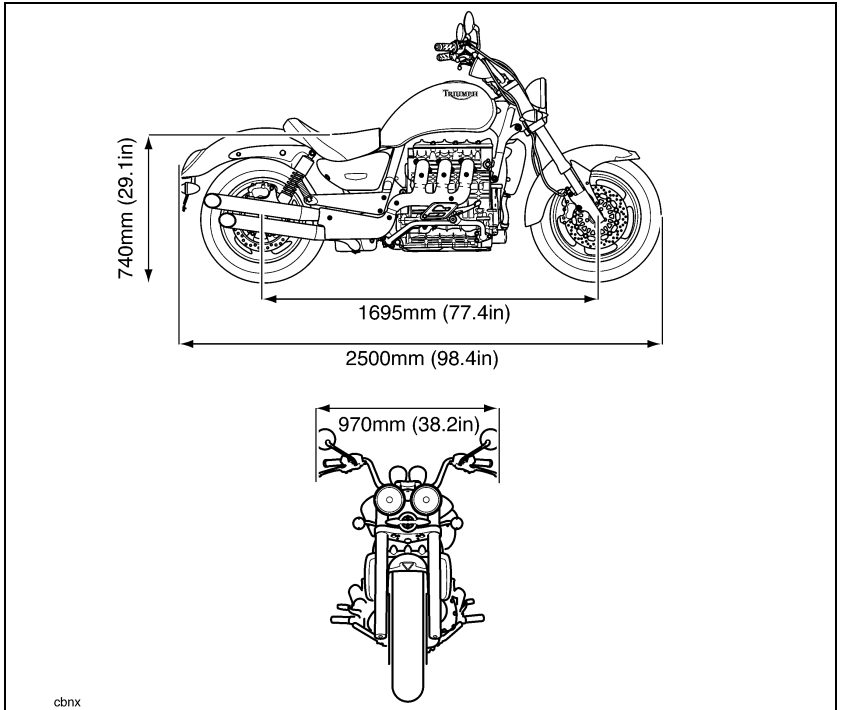

### Weights

Dry Weight	320 kg
Maximum Payload	235 kg

# Specifications

---

## Engine

Type	In-line 3 cyl.
Displacement	2294 cc
Bore x Stroke	101.6 x 94.3 mm
Compression Ratio	8.7:1
Cylinder Sequence	Number 1 at front.
Firing Order	1-2-3

## Performance

Maximum Power (DIN)	142 PS at 5,750 rpm
Maximum Torque	200 Nm at 2,500 rpm

## Lubrication

Lubrication System	Dry sump with remote oil tank
Engine Oil Capacities	
dry fill	5.9 litres
oil/filter change	5.4 litres
oil change only	5.1 litres

## Cooling

Coolant Type	Mobil Antifreeze
Water/anti-freeze ratio	50/50
Coolant Capacity	3.2 litres
Thermostat Opens (nominal)	85°C

## Fuel System

Type	Sequential electronic fuel injection
Fuel Pump	Submerged Electric
Fuel Pressure	3 Bar

## Fuel

Type	95 RON unleaded
Tank Capacity	23.5 litres

## Ignition

Ignition System	Digital electronic
Spark Plug	NGK DPR8EA9, 2 per cylinder
Gap	0.9 mm

## Transmission

Transmission Type	5 speed, constant mesh with transmission damper
Clutch Type	Wet, Multi-Plate
Drive system	Universal-jointed shaft
Final Drive	Bevel geared crown wheel and pinion
Primary Drive Ratio	1.034:1 (91/88)
Gear Ratio:	
1st	2.929:1 (41/14)
2nd	1.947:1 (37/19)
3rd	1.435:1 (33/23)
4th	1.160:1 (29/25)
5th	0.964:1 (27/28)
Secondary Drive Ratio	1.043:1 (48/46)
Final Drive Ratio	2.846:1 (37/13)

# Specifications

---

## Tyres

### Tyre Pressures (Cold)

Front 2.34 Bar (34 lb/in<sup>2</sup>)

Rear 2.90 Bar (42 lb/in<sup>2</sup>)

### Approved tyres

#### Option 1

Front Metzeler ME880 Marathon 150/80 R17

Rear Metzeler ME880 Marathon 240/50 R16

#### Option 2

Front Bridgestone 150/80/17

Rear Bridgestone 240/50 R16



## Warning

Use the recommended tyres ONLY in the combinations given. Do not mix tyres from different manufacturers or mix different specification tyres from the same manufacturers as this may result in loss of motorcycle control and an accident.

## Electrical Equipment

Battery 12 volt, 18 amp-hour

Alternator 37 amps/min at 2,000 rpm,  
41 amps/min at 6,000 rpm

Headlight 2 x 12 volt, 60/55 watt H4 halogen

Tail/Brake Light 12 volt, 5/21 watt

Directional Indicator Lights 12 volt, 10 watt

## Frame

Castor 32°

Trail 152 mm

## Tightening Torques

Oil Filter	8-12 Nm
Oil Tank Drain Plug	25 Nm
Front Sump Plug	25 Nm
Rear Sump Plug	25 Nm
Spark Plug	20 Nm

## Fluids and Lubricants

Engine Oil: Semi or fully synthetic 10W/40 or 15W/50 motorcycle engine oil which meets specification API SH (or higher) and JASO MA, such as Mobil 1 Racing 4T.

Brake and Clutch Fluid	Mobil Universal Brake & Clutch Fluid DOT4
Coolant	Mobil Antifreeze
Bearings and Pivots	Mobil Grease HP 222
Final Drive Oil	Mobilube SHC 75/W-90 fully synthetic hypoid oil

This page intentionally left blank

---

**INDEX****B****Battery, 81**Disposal, **82**Installation, **83**Maintenance, **82**Removal, **81****Brakes, 67**Brake and Clutch Lever  
Adjuster, **25**Brake Wear Inspection, **67**Braking, **39**Disc Brake Fluid, **68**Fluid Inspection and  
Adjustment, **69**Light Switches, **70**Pad Wear Compensation, **67****C****Cleaning, 89**After Washing, **90**Drying, **91**Exhaust System, **91**Preparation for Washing, **89**Protecting, **92**Unpainted Aluminium Items,  
**91**Washing, **91**Where to be Careful, **90****Clutch, 66**Adjustment, **66**Inspection, **66****Cooling, 96****Cooling System, 60**Coolant Change, **62**Corrosion Inhibitors, **60**Level Adjustment, **61**Level Inspection, **61**Radiator Hoses, **62****D****Dimensions, 95****E****Electrical Equipment, 98****Engine**Serial Number, **17**Specifications, **96**To Start the Engine, **37**To Stop the Engine, **36****Engine Oil, 56**Disposal of Oil and Filters, **59**Level Inspection, **56**Oil and Oil Filter Change, **57**Specification and Grade, **60****F****Final Drive Unit, 75**Oil Level Adjustment, **75****Fluids and Lubricants, 99****Frame, 98****Fuel, 97****Fuel Requirement, 28**Filling the Fuel Tank, **30**Fuel Grade, **28**Fuel Tank Cap, **29**Refuelling, **28****Fuel System, 97****Fuse Box, 83**

- Fuse Identification, **84**
- G**
- Gears
  - Changing, **38**
- H**
- Headlights, **85**
  - Bulb Replacement, **86**
  - Horizontal Adjustment, **86**
  - Vertical Adjustment, **85**
- High Speed Operation, **43**
- I**
- Ignition, **97**
  - Ignition Switch/Steering Lock, **24**
  - Key, **24**
- Indicator Lights, **89**
  - Bulb Replacement, **89**
- Instrument Panel Layout, **20**
- L**
- Left Handlebar Switches, **27**
  - Direction Indicator Switch, **27**
  - Headlight Dip Switch, **27**
  - Horn Button, **27**
- Lubrication, **96**
- M**
- Moving Off, **38**
- O**
- Odometer/Trip Meter, **21**
- P**
- Parking, **42**
- Performance, **96**
- R**
- Rear Light, **88**
  - Bulb Replacement, **88**
- Right Handlebar Switches, **26**
  - Engine Stop Switch, **26**
  - Starter Button, **27**
- S**
- Safe Operation, **33**
  - Daily Safety Checks, **33**
- Safety First, **5**
  - Fuel and Exhaust Fumes, **6**
  - Handlebars and Footrests, **11**
  - Maintenance and Equipment, **9**
  - Parking, **8**
  - Parts and Accessories, **8**
  - Riding, **10**
  - Safety Helmet and Clothing, **7**
  - The Motorcycle, **5**
- Scheduled Maintenance, **53**
- Seat Lock, **32**
- Specifications, **95**
- Speedometer, **21**
- Stand, **31**
- Steering/Wheel Bearings, **71**
  - Inspecting for Free-Play, **71**
  - Steering Inspection, **71**
  - Wheel Bearings Inspection, **72**
- Storage, **93**
  - Preparation after Storage, **94**
  - Preparation for Storage, **93**
- Suspension, **73**
  - Suggested Settings, **74**
- T**
- Tachometer, **21**

- Throttle Control, **63**
  - Inspection, **64**
- Tightening Torques, **99**
- Toolkit and Handbook, **31**
- Transmission, **97**
- Tyres, **76**
  - Minimum Tread Depth, **77**
  - Replacement, **78**
  - Specifications, **98**
  - Tyre Inflation Pressures, **76**
  - Tyre Wear, **76**
- V**
- Vehicle Identification Number, **17**
- W**
- Warnings, **1**
  - Information, **3**
  - Maintenance, **2**
  - Noise Control System, **2**
  - Owner's Handbook, **2**
  - Warning Label Locations, **12,**  
**13**
  - Warning Labels, **2**
  - Warning Lights, **22**
  - Warning, Caution and Note, **1**
- Weights, **95**
- Windscreen Cleaning, **70**

[OEM parts & online schematics](#)